

Medium Pressure Piston Pump Variable Displacement Closed Circuit

Model 70160	Model 70360	Model 72400
20.3 cm ³ /r [1.24 in ³ /r]	40.6 cm ³ /r [2.48 in ³ /r]	40.6 cm ³ /r [2.48 in ³ /r]
23.6 cm ³ /r [1.44 in ³ /r]	49.2 cm ³ /r [3.00 in ³ /r]	49.2 cm ³ /r [3.00 in ³ /r]
Pressure rating - bar [psi], Nominal - 350 [5076], Peak- 380 [5500]		



Model 70160



Model 70360

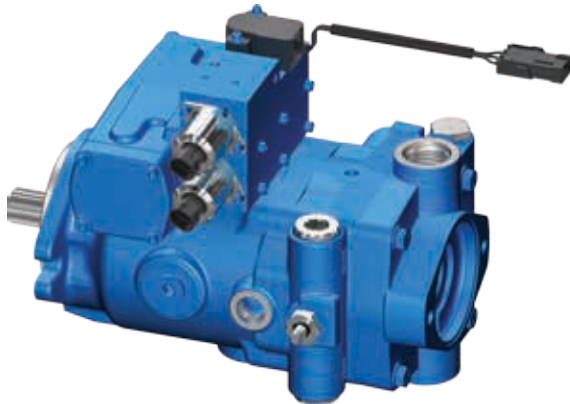

Model 72400

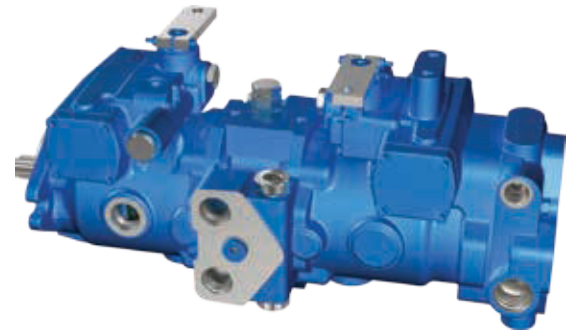

Model 72400 Back to Back



Table of contents

Description	Page No.
Introduction	3
Closed loop system	4
Functional diagram	4
Hydraulic schematic	4
Technical specifications	5
Manual control pumps	6
70160 Series	6
70360 Series	6
Servo controlled	7
72400 Series	7
Model code - Single pump	8 - 17
70160 Series	8
70360 Series	11
72400 Series	14
Model code - Back to Back pumps	18 - 23
70360 Series	18
72400 Series	21
Hydraulic circuits	24 - 25
Single pumps	24
Multiple pumps	24
Pump controls	26
Electronic Proportional displacement control	27 - 29
EP displacement control features	27
Interface schematic	28
Solenoid actuated valve assembly	28
Solenoid operated controls	29
Solenoid control with swash feedback sensor	30
Hydraulic remote control	31
Manual control	32
Pump additional features	33 - 39
Brackets	33
Bleed-off valve	33
Bypass/dump valve	34
Supply and control orifice on model 72400	35
Swash position sensor	36
Speed sensor	37
Adjustable displacement limiter on model 72400	38
Adjustable displacement limiter kit	39
Pump mounting and shafts	40
Auxiliary rear mounts and output shafts	41
Installation dimensions	42 - 43
Single pumps	42
Multiple pumps	43
Back to Back pumps	43
Features and port sizes	44 - 49
Model 70160	44
Model 70360	45
Model 72400	47
Model 72400 charge pump routing and location	49
Component selection	50 - 51
Hydraulic fluid recommendations	52 - 53

Introduction

In axial piston pumps, the pistons reciprocate parallel to the axis of rotation of the cylinder block. The simplest type of axial piston pump is the swash plate in-line design.

The cylinder block in this pump is turned by the drive shaft. Pistons fitted to bores in the cylinder block are connected through piston shoes and a shoe plate, so that the shoes bear against an angled swash plate causing the pistons to reciprocate. The ports are arranged in the valve plate so that the pistons pass the inlet as they are pulled out and pass the outlet as they are forced back in.

The displacement of axial piston pumps is determined by the size and number of pistons, as well as the stroke length which is determined by the angle of the swash plate.

Variable Displacement Piston Pumps are used in closed loop systems either as a single or tandem pump. Oil is circulated by the pump to the motor and then returned directly back to the pump. A charge supply is used to supplement the closed loop system with oil. The charge supply may be supplied by an internal charge pump (standard) or an external source.

Typical applications

Harvester equipment

- Combines
- Fruit or vegetable pickers
- Swathers

Forestry equipment

- Log skidders
- Bark removers
- Limb removers

Construction equipment

- Trenchers
- Skid steer loaders
- Utility vehicles
- Sweepers

Turf care equipment

- Mowers

Paving equipment

- Rollers
- Packers

Industrial equipment

- Lift trucks
- Scissor lifts

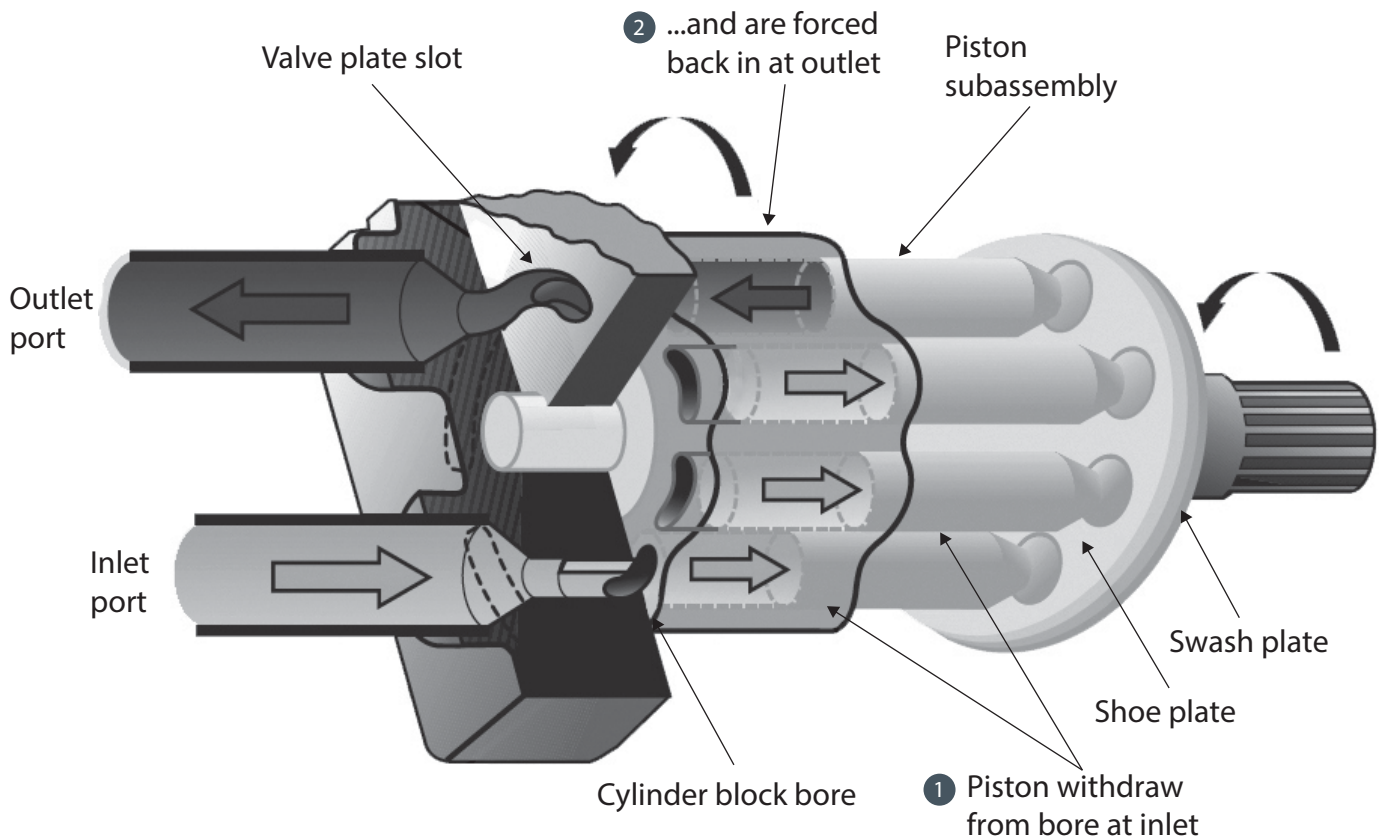

Closed loop system

Functional diagram

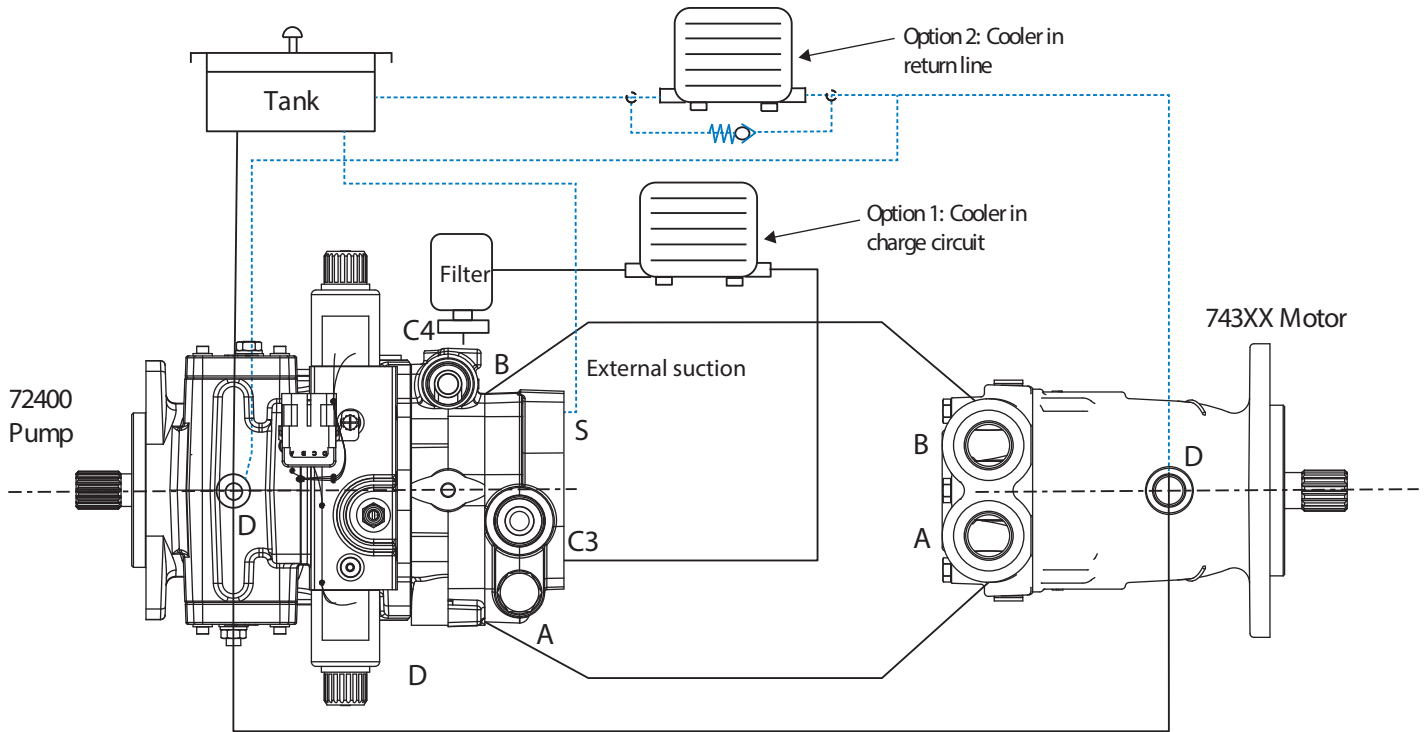

Hydraulic schematic

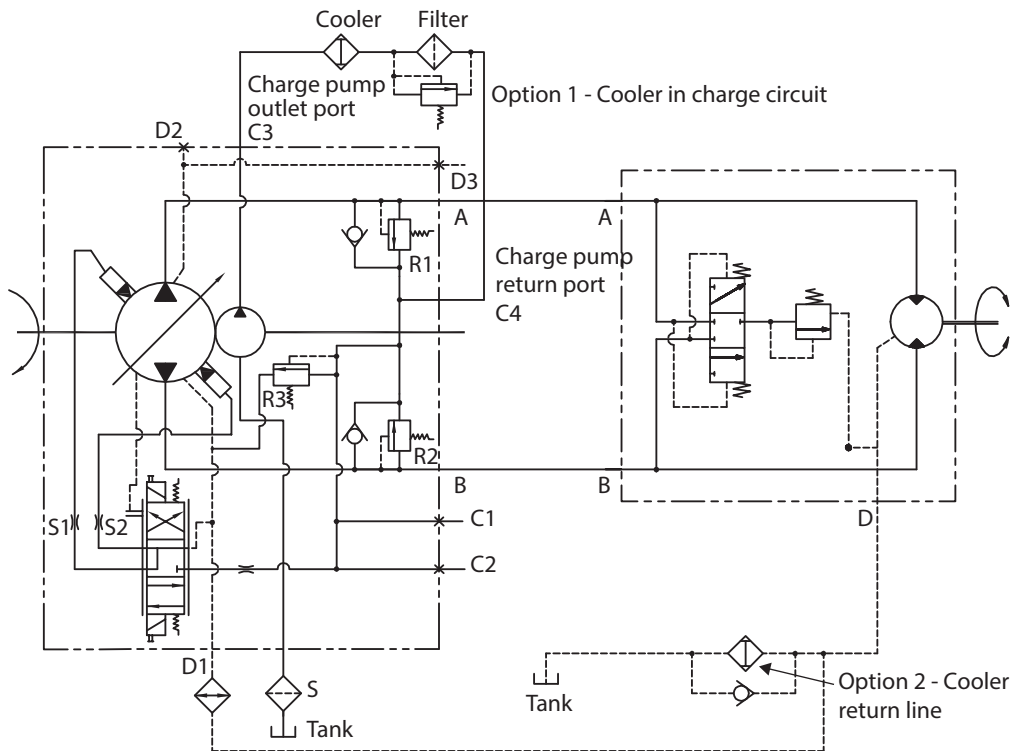

Technical specifications

			70160		70360		72400 / 72400 B2B	
Rated size	Maximum displacement	cm ³ /rev (in ³ /r)	20.3 (1.24)	23.6 (1.44)	40.6 (2.48)	49.2 (3.0)	40.6 (2.48)	49.2 (3.0)
Mount	Front mount flange	SAE	A	A	B	B	B	B
Flow	Flow @ rated speed & PSI	l/min (gal/min)	64.3 (17)	75.7 (20)	140 (37)	169 (44.8)	140 (37)	169 (44.8)
Speed	Maximum rated speed	rpm	3600	3600	3600	3600	3600	3600
Pressure	Nominal pressure rating*	bar (psi)	350 (5076)	350 (5076)	350 (5076)	350 (5076)	350 (5076)	350 (5076)
	Peak pressure rating**	bar (psi)	380 (5500)	380 (5500)	380 (5500)	380 (5500)	380 (5500)	380 (5500)
Power	Max input power (at nominal pressure and rated speed)	kw (HP)	42 (56)	49 (65)	84 (113)	102 (137)	84 (113)	102 (137)
	Max input torque	N-m (lbf-in)	119 (1050)	136 (1200)	237 (2099)	286 (2528)	237 (2099)	286 (2528)
	Continuous allowable case pressure	bar (psi)	2 (29)	2 (29)	2 (29)	2 (29)	2 (29)	2 (29)
	Maximum case drain Temperature	°C (°F)	107 (225)	107 (225)	107 (225)	107 (225)	107 (225)	107 (225)
	Weight per single pump	kg (lbs)	9.5 (21)	9.5 (21)	14 to 16 (31 to 35)	14 to 16 (31 to 35)	27 to 28 (59 to 62)	27 to 28 (59 to 62)
	Integral charge pump displacements	cm ³ /rev (in ³ /r)	6.9 (0.42), 10.3 (0.63), 13.8 (0.84)	6.9 (0.42), 10.3 (0.63), 13.8 (0.84)	6.9 (0.42), 10.3 (0.63)#, 13.8 (0.84), 17.2 (1.05), 20.7 (1.26)	6.9 (0.42), 10.3 (0.63)#, 13.8 (0.84), 17.2 (1.05), 20.7 (1.26)	6.9 (0.42), 10.3 (0.63), 13.8 (0.84), 17.2 (1.05), 20.7 (1.26)	6.9 (0.42), 10.3 (0.63), 13.8 (0.84), 17.2 (1.05), 20.7 (1.26)
	Input shafts		Splined, straight round, tapered		Splined, straight round, tapered		Splined, straight round, tapered	
	Auxiliary mounting options- SAE		A Pad (9T, 11T)		A Pad (9T, 11T), B Pad (13T)		A Pad (9T, 11T), B Pad (13T)	
	Controls		Direct manual		Direct manual		Servo manual, hydraulic pilot, electronic proportional, solenoid	
	Main Ports- SAE O-ring, radial		Same side, opposite side		Same side, opposite side		Same side	
	Additional options		Bleed off-valve, bypass valve, shuttle & back pressure relief valve		Bleed off-valve, bypass valve, swash position sensor		Bypass valve, swash position sensor, speed sensor, displacement limiter, neutral lock-out, de-stroke valve	
Moment of Inertia	Single pump (rotating kit and shaft)	kg*m ²	1.16E-03	1.16E-03	2.73E-03	2.73E-03	2.60E-03	2.60E-03
	Two pumps (two rotating kits and shafts)	kg*m ²	2.33E-03	2.33E-03	5.46E-03	5.46E-03	5.27E-03	5.27E-03
	G load capacity (single pump)***		10G	10G	10G	10G	10G	10G

* Nominal pressure: Max delta system working pressure (pump life estimated by bearing life).

** Peak pressure: Max operation pressure which is permissible for a short duration of time (t < 1 sec).

*** Please contact Danfoss representative for specific requirements.

Available on request.

Centre of gravity

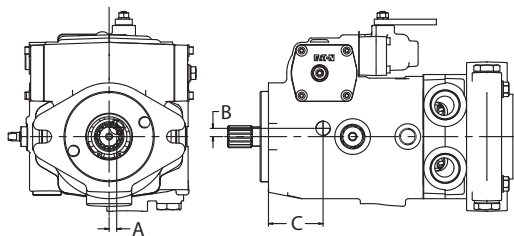

C.G. with respect to mounting face and shaft axis

Dimension - mm (inch)	Single			Tandem		B2B	
	70160	70360	72400	70360	72400	70360	72400
A	3.7 (0.146)	0.33 (0.013)	2.28 (0.09)	0.13 (0.0052)	-1.2 (0.047)	0.18 (0.007)	0.15 (0.0058)
B	3.25 (0.128)	3.0 (0.121)	33.5 (1.32)	3.638 (0.145)	17.78 (0.70)	5.13 (0.2)	18.74 (0.738)
C	111 (4.374)	98.45 (3.876)	110 (4.29)	212.6 (8.37)	253.75 (9.99)	242.6 (9.55)	230.7 (9.084)

Manual control pumps



70160 Series

- 20.3 cm³/r [1.24 in³/r]
- 21.6 cm³/r [1.32 in³/r]
- 23.6 cm³/r [1.44 in³/r]



70360 Series

- 35.1 cm³/r [2.1 in³/r]
- 40.6 cm³/r [2.48 in³/r]
- 49.2 cm³/r [3.00 in³/r]

Features and benefits

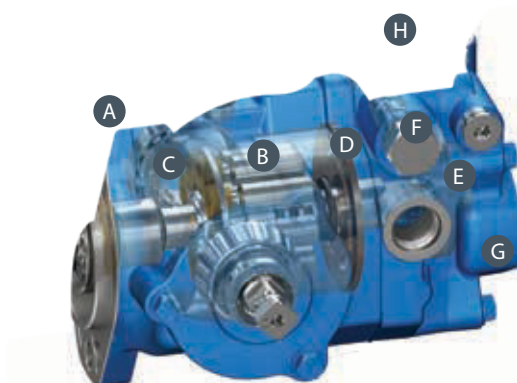

- A** Housing
 - Compact
 - Lightweight, die cast aluminum
- B** Rotating kit
 - 20.3 to 49.2 cm³/r [1.24 to 3.0 in³/r] displacements
- C** Swash plate
 - With swash position sensor (on 70360)
- D** Valve plate
 - Reduces noise & swash plate moments
 - Improves mechanical efficiency
 - Improved serviceability
- E** Ge-rotor charge pump
 - 6.9 cm³/r [.42 in³/r]
 - 10.3 cm³/r [.63 in³/r]
 - 13.8 cm³/r [.84 in³/r]
 - 17.2 cm³/r [1.05 in³/r]
 - 20.7 cm³/r [1.26 in³/r]
- F** High pressure relief valve
 - 104 to 350 bar [1500 to 5500 psi]
- G** Charge pump housing w/ auxiliary mount
 - SAE A or B
 - To mount additional pump
- H** Bypass valve
 - For cross porting & towing to a limited distance

Servo controlled



72400 Series

- 40.6 cm³/r [2.48 in³/r]
- 49.2 cm³/r [3.00 in³/r]

Features and benefits

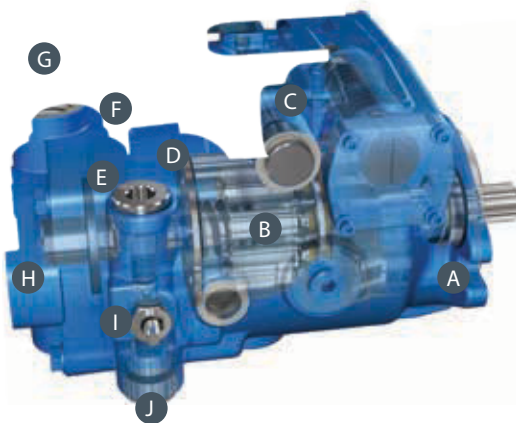

- A** Housing
 - Compact
 - Durable cast iron design
 - Multiple drain options
 - Improved serviceability
- B** Rotating group
 - 40.6 cm³/r [2.48 in³/r]
 - 49.2 cm³/r [3.00 in³/r]
- C** Manual displacement servo control valve
 - Low operator effort.
 - Modular design
- D** Valve plate
 - Quieter operation
 - Improved serviceability
 - Improves mechanical efficiency
- E** Ge-rotor charge pump
 - 6.9 cm³/r [.42 in³/r]
 - 10.3 cm³/r [.63 in³/r]
 - 13.8 cm³/r [.84 in³/r]
 - 17.2 cm³/r [1.05 in³/r]
 - 20.7 cm³/r [1.26 in³/r]
- F** End cover with main ports on
 - Same side
 - Opposite side
- G** Charge pressure relief valve
- H** Auxiliary pump mounting flange
 - SAE "A" or "B"
- I** Bypass valve
 - For cross porting & towing to a limited distance
- J** High pressure relief valve
 - 104 to 350 bar [1500 to 5500 psi]

Model code - Single pump

70160 Series

The Model 70160 variable displacement piston pumps are specified by the following model code. Once a pump is built from the model code, a product number will be assigned to that configuration.

Make sure all positions are selected within the 32 digit code for each pump.

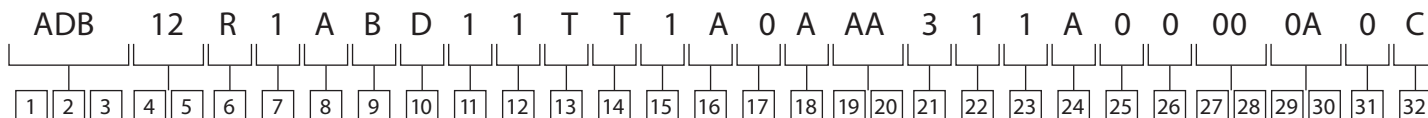

ADB - Series 70160 manually variable displacement axial piston pump with SAE J744 flange 82-2 (2 Bolt A)

All left (CCW) or right (CW) directions given are viewed from the input shaft end of the pump

	Code	Single unit	Tandem front	Unit rear
Positions 4, 5 - Displacement				
12 = 20.3 cm ³ /r [1.24 in ³ /r]	12	Std.	Std.	Std.
13 = 21.6 cm ³ /r [1.32 in ³ /r]	13	Std.	Std.	Std.
14 = 23.6 cm ³ /r [1.44 in ³ /r]	14	Std.	Std.	Std.
Position 6 - Input shaft rotation				
R = Righthand rotation (CW)	R	Std.	Std.	Std.
L = Lefthand rotation (CCW)	L	Std.	Std.	Std.
Position 7 - Valve plate				
1 = Type 1	1	Std.	Std.	Std.
Position 8 - Input shaft				
A = 13 tooth 16/32 pitch spline, shaft extension 41.1 [1.62]	A	Std.	Std.	NA
C = 35 tooth 48/96 pitch spline, shaft extension 32.0 [1.26]	C	NA	NA	Std.
D = 15 tooth 16/32 pitch spline, shaft extension 41.1 [1.62]	D	Opt.	Opt.	NA
F = Straight shaft dia. 22.2 [.875], keyway 6.35 [.25] x 25.9 [1.02], shaft extension 41.1 [1.62] (key included)	F	Opt.	NA	NA
G = 0.125:1 taper, 1" dia, keyed, shaft extension 33.3 [1.31]	G	Opt.	Opt.	NA
Position 9 - Control shaft and location				
L = Left side	L	Std.	Std.	Std.
R = Right side	R	Std.	Std.	Std.
Position 10 - Control shaft				
A = Round with arm diameter 17.32 [.682]; thru cross hole diameter 6.35 [.250], 113 [4.45] from unit centerline to control shaft end	A	Std.	Std.	Std.
B = With diameter 18.75 [.750] taper .125:1, keyway 4.78 x 19.8 [.188 x .78] and .3125-24 UNF-2B, 12.2 [.48] minimum full thread (key included); 113 [4.45] from unit centerline to control shaft end	B	Std.	Std.	Std.
D = With 15.7 [.62] square arm, with bolt groove; 113 [4.45] from unit centerline to control shaft end	D	Std.	Std.	Std.
G = With 15.7 [.62] square arm, and radius 4.83 [.190] locking bolt groove; M8 x 1.25-6H 12.2 [.48] min full G thread; 113 [4.45] from unit centerline to control shaft end	G	Std.	Std.	Std.
Position 11 - Main ports (A and B) location				
1 = Opposite sides	1	Std.	Std.	Std.
2 = Same side (without internal charge pump)	2	Opt.	Opt.	Opt.
Position 12 - Main ports (A and B) Size				
1 = 1- 1/16-12 UN-2B port, SAE straight thread O-Ring ports	1	Std.	Std.	Std.
2 = 7/8-14 UNF-2B port, SAE straight thread O-Ring ports	2	Opt.	Opt.	Opt.
Positions 13, 14 - Relief valve vetting for main ports (select a setting for port "A" in position 10 and port "B" in position 11.)				
0 = No relief, check valve assembly only	0	Opt.	Opt.	Opt.
B = 138 bar [2000 PSI]	B	Opt.	Opt.	Opt.
E = 173 bar [2500 PSI]	E	Opt.	Opt.	Opt.
H = 207 bar [3000 PSI]	H	Opt.	Opt.	Opt.
L = 241 bar [3500 PSI]	L	Opt.	Opt.	Opt.
N = 276 bar [4000 PSI]	N	Opt.	Opt.	Opt.
Q = 310 bar [4500 PSI]	Q	Opt.	Opt.	Opt.
T = 344 bar [5000 PSI]	T	Std.	Std.	Std.

Dimensions are in mm [in] unless noted otherwise.

Model code - Single pump

70160 Series

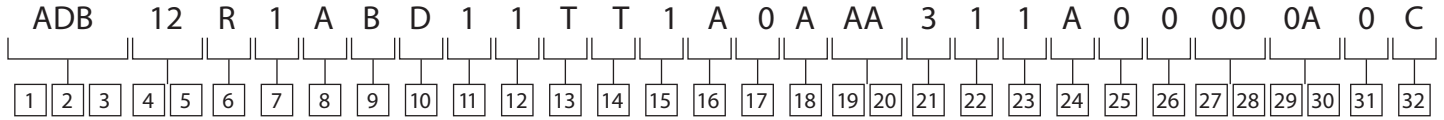

	Code	Single unit	Tandem front	Unit rear
Position 15 - Charge displacement, suction port (S)				
0 = No charge	0	Opt.	Std.	Opt.
1 = 6.9 cm ³ /r [.42 in ³ /r]; 3/4 - 16 UNF-2B SAE O-Ring port for suction inlet (right side CCW, left side CW)	1	Std.	NA	NA
2 = 10.3 cm ³ /r [.63 in ³ /r]; (.750-16 UNF-2B SAE O-Ring for suction inlet(right side CCW, left side CW)	2	Opt.	NA	Opt.
3 = 13.8 cm ³ /r [.84 in ³ /r]; 3/4 -16 UNF-2B SAE O-Ring port for suction inlet (right side CCW, left side CW)	3	Opt.	NA	Std.
Position 16 - Charge relief setting and routing				
0 = No (requires external relief set between 6.89 bar [100 lbf/in] and 20.68 bar [300 lbf/in)	0	Opt.	Std.	Opt.
A = 6.89-10.34 bar [100-150 PSI]; relieved to case	A	Std.	NA	Std.
B = 10.34-13.79 bar [150-200 PSI]; relieved to case	B	Opt.	NA	Opt.
C = 13.79-17.24 bar [200-250 PSI]; relieved to case	C	Opt.	NA	Opt.
D = 17.24-20.68 bar [250-300 PSI]; relieved to case	D	Opt.	NA	Opt.
E = 20.68-24.13 bar [300-350 PSI]; relieved to case	D	Opt.	NA	Opt.
F = 6.89-10.34 bar [100-150 PSI]; recirculated	F	Std.	NA	Std.
G = 10.34-13.79 bar [150-200 PSI]; recirculated	G	Opt.	NA	Opt.
H = 13.79-17.24 bar [200-250 PSI]; recirculated	H	Opt.	NA	Opt.
J = 17.24-20.68 bar [250-300 PSI]; recirculated	J	Opt.	NA	Opt.
L = 4.14-7.58 bar [60-110 lbf/in]; relieved to case	L	Opt.	NA	Opt.
P = 11.38-14.82 bar [165-215 lbf/in]; recirculated	P	Opt.	NA	Opt.
Position 17 - Charge special feature				
0 = No special feature	0	Std.	Std.	Std.
Position 18 - Auxiliary rear mount and output shaft				
A = With integral charge: horizontal 2-Bolt "A" SAE J744 flange 82-2; accepts 9 tooth internal 16/32 pitch A spline with 31.7 [1.25] shaft extension		Std.	NA	Std.
B = No integral charge: horizontal or vertical 2-Bolt "A" SAE J744 flange 82-2; accepts 11 tooth external 16/32 pitch spline with 31.7 [1.25] shaft extension (coupler required)		Opt.	NA	Opt.
C = No integral charge: horizontal or vertical 2-Bolt "A" SAE J744 flange 82-2; Accepts 9 tooth external 16/32 pitch spline with 31.7 [1.25] shaft extension (coupler required)		Opt.	NA	Opt.
D = No integral charge: horizontal or vertical 2-Bolt "A" SAE J744 flange 82-2; Accepts 35 tooth external 48/96 pitch spline with 32 [1.26] shaft extension (coupler required)		Opt.	NA	Opt.
E = No integral charge: horizontal or vertical 2-Bolt "A" SAE J744 flange 82-2; Accepts 9 tooth external 20/40 pitch spline with 31.7 [1.25] shaft extension (coupler required)		Opt.	NA	Opt.
G = With integral charge; horizontal SAE A 2 Bolt A, accepts 11T internal 163/32 spline with 31.7 [1.25] shaft extension		Std.	NA	Opt.
Position 19, 20 - Special features auxiliary mounting				
00 = No special features	AA	Opt.	Std.	Opt.
AA = Supply cover plate for 2-Bolt "A" SAE J744 flange 82-2	AB	Opt.	NA	Opt.
AB = Supply shaft coupler 9 tooth 16/32 pitch	AC	Opt.	NA	Opt.
AC = Supply shaft coupler 9 tooth 20/40 pitch	AD	Opt.	NA	Opt.
AD = Supply shaft coupler 11 tooth 16/32 pitch	AE	Opt.	NA	Opt.
AE = Supply shaft coupler 35 tooth 48/96 pitch	AF	Opt.	Opt.	Opt.
AF = Bottom mounting bracket (632), Square Shaped	AG	Opt.	Opt.	Opt.
AG = Bottom mounting bracket (709), V Shaped	AH	Opt.	Opt.	Opt.
AH = Auxiliary mounting holes, 2 holes .375-16 UNC-2B thread, 15 [.59] min full thread, both sides (9T coupler and mounting holes)	AH	Opt.	Opt.	Opt.
Position 21 - Auxiliary port top-front (C1) or bypass valve				
0 = None	0	Std.	Std.	Std.
1 = 3/4 -16 UNF-2B SAE o-ring port	1	Opt.	Opt.	Opt.
2 = 3/4 -16 UNF-2B SAE o-ring port plugged	2	Opt.	Opt.	Opt.
3 = Bypass valve installed	3	Opt.	Opt.	Opt.

Dimensions are in mm [in] unless noted otherwise.

Model code - Single pump

70160 Series

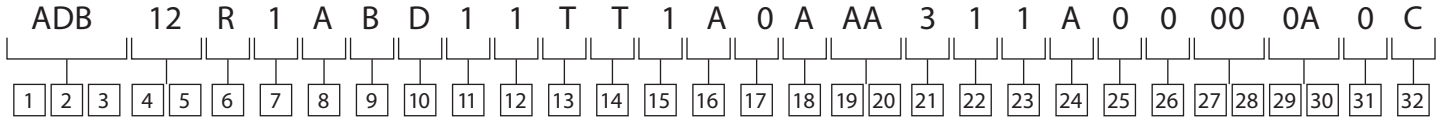

	Code	Single unit	Tandem front	Unit rear
Position 22 - Auxiliary port top-rear (C2)				
0 = None	0	Std.	Std.	Std.
1 = 3/4 -16 UNF-2B SAE o-ring port	1	Std.	Opt.	Opt.
2 = 3/4 -16 UNF-2B SAE o-ring port plugged	2	Opt.	Opt.	Opt.
Position 23 - Auxiliary port side (C4 or C5) (integral charge only)				
0 = None	0	Opt.	NA	Opt.
1 = 3/4 -16 UNF-2B SAE o-ring port (right side CW, left side CCW)	1	Opt.	NA	Opt.
Position 24 - Case drain (D1 and D2)				
A = 3/4 -16 UNF-2B SAE o-ring port D1-top (D2-bottom plugged)	A	Std.	Opt.	Std.
B = 3/4 -16 UNF-2B SAE o-ring port D2-bottom (D1-top plugged)	B	Opt.	Opt.	Opt.
C = 3/4 -16 UNF-2B SAE o-ring port (D1-top plugged and D2-bottom plugged)	C	Opt.	Opt.	Opt.
D = 3/4 -16 UNF-2B SAE o-ring port (D1-top and D2-bottom open)	D	Opt.	Opt.	Opt.
Position 25 - Thru drain (D3 and D4)				
0 = None	0	Opt.	Opt.	Opt.
A = .365 Dia. D3-rear	A	Opt.	Std.	Opt.
B = .376 Dia. D4-front	B	Opt.	Opt.	Std.
C = .365 Dia. D3-rear and .376 Dia. D4-front	C	Opt.	Opt.	Opt.
Position 26 - Additional functions				
0 = None	0	Std.	Std.	Std.
A = Bleed-off valve in control shaft position "a" set at 13.79-17.24 bar [200-250 lbf/in	A	Opt.	Opt.	Opt.
B = Bleed-off in control shaft position "b", 13.79-17.24 bar [200-250 lbf/in	B	Opt.	Opt.	Opt.
C = Bleed-off in control shaft position a and b 13.79-17.24 bar [200-250 lbf/in	C	Opt.	Opt.	Opt.
D = Integral Shuttle Valve and Back-Pressure Valve set at 6.9-9 bar [100-130 lbf/in	D	Opt.	Opt.	Opt.
Position 27, 28 - Special features				
00 = None	00	Std.	Std.	Std.
0A = Fluorocarbon rubber drive shaft seal	0A	Opt.	Opt.	Opt.
0D = Polyacrylate drive shaft seal	0D	Opt.	Opt.	Opt.
Position 29, 30 - Paint				
0A = Primer, red Oxide	0A	Std.	Std.	Std.
0B = Black	0B	Opt.	Opt.	Opt.
CD = Primer, blue	CD	Opt.	Opt.	Opt.
Position 31 - Identification				
0 = Standard: Nameplate	0	Std.	Std.	Std.
Position 32 - Design code				
C = C	C	Std.	Std.	Std.

Dimensions are in mm [in] unless noted otherwise.

Model code - Single pump

70360 Series

Ordering Instructions: The Model 70360 piston pumps are specified by using the following model code system tailoring the pump configuration to the requirement. Once a pump is built from the model code, a product number will be assigned to that configuration and the pump identified.

Make sure all positions are selected within the 25 digit code for each pump order. Also state if the pumps making up a tandem are required to be mounted together or separately.

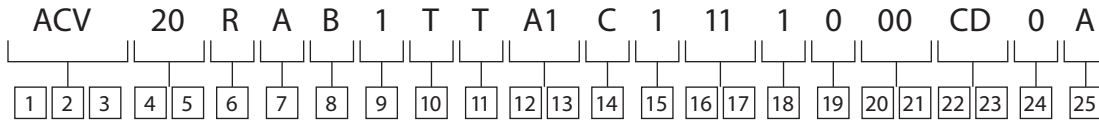

ACV - Series 70360 manually variable displacement axial piston pump

All left (CCW) or right (CW) directions given are viewed from the input shaft end of the pump

	Code	Single unit	Tandem front	Unit rear
Positions 4, 5 - Displacement				
10 = 35.1 cm ³ /r [2.10 in ³ /r]; Rotating kit-standard; valve plate - type 1	10	Std.	Std.	Std.
20 = 40.6 cm ³ /r [2.48 in ³ /r]; Rotating kit-standard; valve plate - type 1	20	Std.	Std.	Std.
30 = 49.2 cm ³ /r [3.00 in ³ /r]; Rotating kit-standard; valve plate - type 1	30	Std.	Std.	Std.
Position 6 - Input shaft rotation				
L = Lefthand rotation (CCW)	L	Std.	Std.	Std.
R = Right-hand rotation (CW)	R	Std.	Std.	Std.
Position 7- Input shaft				
A = 15 tooth external spline, 16/32 pitch; 24.981 [.9835] major dia.; 46 [1.81] shaft extension	A	Std.	Std.	NA
B = 41 tooth external spline, 48/96 pitch; 22.2 [.875] major dia.; 24.4 [.96] shaft extension	B	NA	NA	Std.
C = 13 tooth external spline, 16/32 pitch; 21.81 [.8585] major dia.; 41.1 [1.62] shaft extension	C	Opt.	NA	NA
D = 125 :1 taper; 25.4 [1.00] diameter; 6.1 [.25] W x 19.8 [.78] L keyway; 3/8 - 24 UNF -2B Thread; 35, 1 [1.38] Shaft extension	D	Opt.	Opt.	NA
E = Straight 22.2 [.875] diameter; 6.3 [.25] W x 24.6 [.97] L key; 41.3 [1.62] shaft extension	E	Opt.	NA	NA
G = Straight 25.4 [1.00] dia.; 6.1 [.25] x 28.4 [1.12] L key, 46.0 [1.81] shaft extension	G	Opt.	NA	NA
Position 8 - Control shaft and location				
J = Right; 19 [.748] square shaft with bolt groove; 128 [5.04] from centerline to control shaft end	J	Std.	Std.	Std.
K = Left; 19 [.748] square shaft with bolt groove; 128 [5.04] from centerline to control shaft end	K	Std.	Std.	Std.
L = Right; 19.1 [.75] square shaft with bolt groove; 134.1 [5.28] from centerline to control shaft end	L	Std.	Std.	Std.
Position 9 - Main ports (A and B), size and location				
1 = 1 - 1/16 - 12 SAE straight thread, opposite sides	1	Std.	Std.	Std.
2 = 1 - 1/16 - 12 SAE straight thread, same side (without internal charge pump)	2	Opt.	Opt.	Opt.
Positions 10, 11 - Relief valve setting for main port (select a setting for port "A" in position 10 and for port "B" in position 11.)				
0 = Check valve only	0	Opt.	Opt.	Opt.
B = 138 bar [2000 PSI]	B	Opt.	Opt.	Opt.
E = 173 bar [2500 PSI]	E	Opt.	Opt.	Opt.
H = 207 bar [3000 PSI]	H	Opt.	Opt.	Opt.
L = 241 bar [3500 PSI]	L	Opt.	Opt.	Opt.
N = 276 bar [4000 PSI]	N	Opt.	Opt.	Opt.
Q = 310 bar [4500 PSI]	Q	Opt.	Opt.	Opt.
T = 344 bar [5000 PSI]	T	Std.	Std.	Std.
Positions 12, 13 - Auxiliary mount and output shaft (rear)				
A1 = SAE J744 flange 82-2 (2 Bolt A); accepts 9 tooth 16/32 DP spline with 31.7 [1.25] shaft extension (no coupler required)	A1	Std.	Opt.	Std.
A2 = SAE J744 flange 82-2 (2 Bolt A) with cover plate; accepts 9 tooth 16/32 DP spline with 31.7 [1.25] shaft extension (No coupler required)	A2	Opt.	NA	Opt.
A3 = SAE J744 flange 82-2 (2 Bolt A); Accepts 11 tooth 16/32 DP spline with 31.7 [1.25] shaft extension (coupler required)	A3	Opt.	NA	Opt.
A4 = SAE J744 flange 82-2 (2 Bolt A) with cover plate; accepts 11 tooth 16/32 DP spline with 31.7 [1.25] shaft extension (coupler required)	A4	Opt.	NA	Opt.

NA = Not available Opt. = Optional Std. = Standard

Model code - Single pump

70360 Series

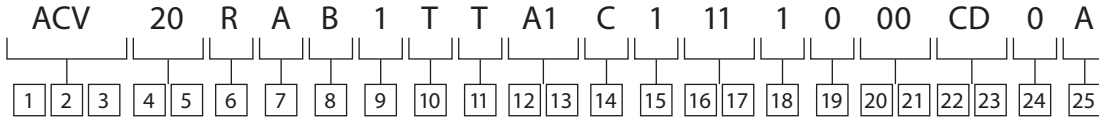

	Code	Single unit	Tandem front	Unit rear
B1 = Horizontal SAE J744 flange 101-2 (2 Bolt B); accepts 13 tooth 16/32 pitch spline with 17.8 [.70] shaft ext (coupler required)	B1	NA	NA	Opt.
B4 = Vertical accepts a SAE J744 flange 101-2 (2 Bolt B); accepts 41 tooth 48/96 DP spline	B4	NA	NA	Opt.
Position 14 - Auxiliary port and bypass valve				
No bypass valve installed				
0 = No auxiliary port	0	Opt.	NA	NA
A = 3/4 - 16 UNF - 2B SAE O-Ring port, top (C1)	A	Opt.	Opt.	Std.
B = 3/4 - 16 UNF - 2B SAE O-Ring port, top w/ hex plug (C1)	B	Opt.	NA	Opt.
G = 3/4 - 16 UNF - 2B SAE O-Ring port, top w/ hex plug (C1); rear-Left 45° (C4)	G	Opt.	Std.	Opt.
L = 3/4 - 16 UNF - 2B SAE O-Ring port, top (C1); rear w/ hex socket plug (C3)	L	Opt.	NA	Opt.
M = 3/4 - 16 UNF - 2B SAE O-Ring port, rear (C3)	M	Opt.	NA	Opt.
V = 3/4 - 16 UNF - 2B SAE O-Ring port, top w/ hex plug (C1), top - rearward (C2)	V	Opt.	NA	Opt.
Y = .750-16 UNF-2B SAE O-Ring port, top w\ hex plug (C1), top-rearward w\ hex plug (C2); No dump valve	Y	Opt.	NA	Opt.
Bypass Valve installed in top port (C1)				
C = 3/4 - 16 UNF - 2B SAE O-Ring port, top rearward (C2)	C	Opt.	Opt.	Opt.
E = 3/4 - 16 UNF - 2B SAE O-Ring port, top (C1); rear left 45° (C4)	E	Opt.	Opt.	Opt.
S = 3/4 - 16 UNF - 2B SAE O-Ring port, top w/ hex plug (C2)	S	Opt.	NA	Opt.
Bypass Valve installed in rear port (C3)				
D = 3/4 - 16 UNF - 2B SAE O-Ring port, top (C1)	D	Opt.	NA	Opt.
U = 3/4 - 16 UNF - 2B SAE O-Ring port, top (C1)	U	Opt.	NA	Opt.
Position 15 - Charge pump				
0 = No charge pump	0	Opt.	Std.	Opt.
1 = 6.9 cm ³ /r [.42 in ³ /r]; 3/4-16 UNF - 2B SAE O-Ring port for suction inlet (S)	1	Std.	NA	NA
2 = 13.8 cm ³ /r [.84 in ³ /r]; 3/4-16 UNF - 2B SAE O-Ring port for suction inlet (S)	2	Opt.	NA	Std.
5 = 17.2 cm ³ /r [1.05 in ³ /r]; 1 5/16-12 UN - 2B SAE O-Ring port for suction inlet (S)- B pad only	5	Std.	NA	Std.
6 = 20.7 cm ³ /r [1.26 in ³ /r]; 1 5/16-12 UN - 2B SAE O-Ring port for suction inlet (S)- B pad only	6	Std.	NA	Std.
Position 16, 17 - Charge pump relief setting and routing				
00 = None	00	Opt.	Std.	Opt.
01 = No charge relief (requires external relief set between 6.89 bar [100 PSI] 17.24 bar [250 PSI])	01	Opt.	Opt.	Opt.
For units with charge pump				
11 = 6.89-10.34 bar [100-150 PSI]; recirculated	11	Std.	NA	Std.
12 = 10.34-13.79 bar [150-200 PSI]; recirculated	12	Opt.	NA	Opt.
13 = 13.79-17.24 bar [200-250 PSI]; recirculated	13	Opt.	NA	Opt.
14 = 17.24-20.68 bar [250-300 PSI]; recirculated	14	Opt.	NA	Opt.
For Units without charge pump				
20 = 4.14-7.59 bar [60-110 lbf/in ²]; relieved to case	20	Opt.	NA	Opt.
21 = 6.89-10.34 bar [100-150 PSI]; relieved to case	21	Opt.	NA	Opt.
22 = 10.34-13.79 bar [150-200 PSI]; relieved to case	22	Opt.	NA	Opt.
23 = 13.79-17.24 bar [200-250 PSI]; relieved to case	23	Opt.	NA	Opt.
Position 18 - Drain port size and location				
0 = 3/4 - 16 UNF - 2B SAE O-Ring port, top (D1); bottom plugged (D2); thru drain in front mounting flange (D4)	0	NA	NA	Std.
1 = 3/4-16 UNF-2B SAE O-Ring port, top (D1); bottom, plugged (D2)	1	Std.	Std.	Opt.

NA = Not available Opt. = Optional Std. = Standard

Model code - Single pump

70360 Series

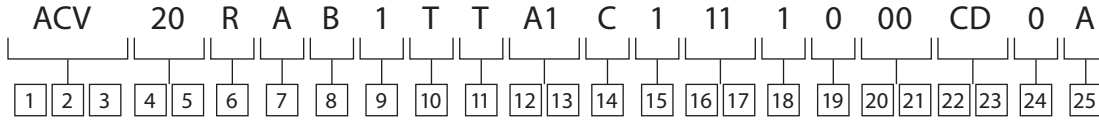

	Code	Single unit	Tandem front	Unit rear
Position 19 - Additional functions				
0 = None	0	Std.	Std.	Std.
A = Bleed-off in control shaft pos a, 6.9-10.3 bar [100-150] lbf/in	A	Std.	Std.	Std.
B = Bleed-off in control shaft pos b, 6.9-10.3 bar [100-150] lbf/in	B	Std.	Std.	Std.
D = Bleed-off in control shaft position "a" 13.8-17.2 bar [200-250] lbf/in	D	Opt.	Opt.	Opt.
E = Bleed-off in control shaft position "b" 13.8-17.2 bar [200-250] lbf/in	E	Opt.	Opt.	Opt.
F = Bleed-off in control shaft position "a" & "b" 13.8-17.2 bar [200-250] lbf/in	F	Opt.	Opt.	Opt.
Positions 20, 21 - Special features				
00 = None	00	Std.	Std.	Std.
OA = Fluorocarbon rubber drive shaft seal and control shaft seal	OA	Opt.	Opt.	Opt.
OC = Bottom mounting bracket with 13.7 [.54] diameter hole	OC	NA	NA	Std.
OD = Coupling and o-ring included for rear mount	OD	Opt.	Opt.	Opt.
OJ = Fluorocarbon rubber drive shaft seal	OJ	Opt.	Opt.	Opt.
OK = O-Ring included for rear mount	OK	Opt.	NA	Opt.
OW = High strength rotating kit with swash sensor	OW	Opt.	Opt.	Opt.
OY = High strength rotating kit with swash sensor & fluorocarbon rubber drive shaft seal	OY	Opt.	Opt.	Opt.
Positions 22, 23 - Paint				
OA = Primer	OA	Std.	Std.	Std.
OB = Black	OB	Opt.	Opt.	Opt.
Position 24 - Identification				
0 = Standard (nameplate)	0	Std.	Std.	Std.
Position 25 - Design code				
B = B	B	Std.	Std.	Std.

NA = Not available Opt. = Optional Std. = Standard

Model code - Single pump

72400 Series

Ordering Instructions: The Model 72400 Servo Controlled piston pumps are selected by using the following Model Code System tailoring the pump configuration to the requirement. Once a pump is built from the model code, a product number will be assigned to that

configuration and the pump identified.

Make sure all positions are selected within the 27-digit code for each pump ordered.

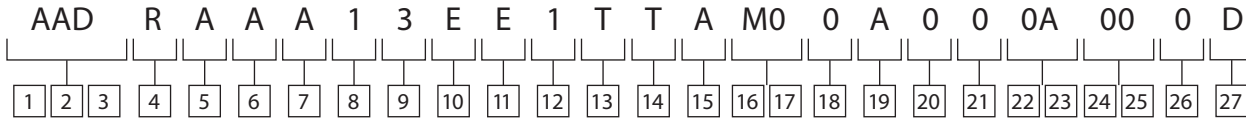

AAE = 40.6 cm³/r [2.48 in³/r] Series 72400 servo controlled variable displacement axial piston pump

AAF = 40.6 cm³/r [2.48 in³/r] servo controlled variable displacement pump (tandem front pump)

ACH = 49.2 cm³/r [3.00 in³/r] Series 72400 servo controlled variable displacement axial piston pump

ACH = 49.2 cm³/r [3.00 in³/r] Servo controlled variable displacement pump (tandem front pump)

ACJ = 49.2 cm³/r [3.00 in³/r] servo controlled variable displacement pump (tandem rear pump)

All left (CCW) or right (CW) directions given are viewed from the input shaft end of the pump

	Code	Single unit	Tandem front	Unit rear
Position 4 - Input shaft rotation				
L = Left hand rotation (CCW)	L	Std.	Std.	Std.
R = Right-hand rotation (CW)	R	Std.	Std.	Std.
Position 5- Input shaft				
A = 15 tooth, 16/32 external spline, 46 [1.81] shaft extension	A	Std.	Std.	NA
C = 13 tooth, 16/32 external spline, 41.1 [1.62] shaft extension	C	Opt.	NA	NA
D = Taper 1.502:12, 6.4 [.25] x 19.8 [.78] keyway, 3/8 - 24 UNF int. thread, 35.1[1.38] shaft extension	D	Opt.	Opt.	NA
G = 25.4 [1.00] Dia. straight, 6.4 [.25] x 28.4 [1.12] keyway, 46 [1.81] shaft extension (key included)	G	Opt.	NA	NA
Position 6 - Output shaft				
0 = No output shaft				
A = 9 tooth, 16/32 internal spline, accepts 31.8 [1.25] shaft extension (for SAE "A" mount only)	A	Std.	NA	Std.
B = 41 tooth, 48/96 external spline, accepts 24.4 [.96] shaft extension (for SAE "B" mount only)	B	NA	Std.	NA
F = 11 tooth, 16/32 internal spline, accepts 31.8 [1.25] shaft extension (for SAE "A" mount only)	F	Opt.	NA	Opt.
J = 11 tooth, 16/32 external spline, accepts 31.8 [1.25] shaft extension (for SAE "B" mount only) (to be used with 36.8 [1.45] spacer)	J	Opt.	NA	Opt.
G = 13 tooth 16/32 external spline, accepts 17.8 [.70] shaft extension (No charge pump)	G	Opt.	NA	Opt.
H = 35 tooth 48/96 external spline, to be used with spacer to accept 24.4 [.96] shaft extension	H	Opt.	NA	Opt.
Position 7 - Auxiliary rear mounting				
A = "A" SAE flange series 82-2	A	Std.	NA	Opt.
B = 2 Bolt "B" SAE flange series 101-2	B	Opt.	Std.	Opt.
C = "A" SAE flange series 82-2 w/ cover plate	C	Opt.	NA	Opt.
D = "A" SAE flange series 82-2 w/ cover plate and mounting support holes	D	Opt.	NA	Opt.
E = "A" SAE flange series 82-2 w/ mounting support holes	E	Opt.	NA	Std.
F = 2 Bolt "B" SAE flange series 101-2 w/ mounting support holes	F	Opt.	Opt.	Opt.
J = 2 Bolt B SAE flange series 101-2, with charge adaptor	J	Opt.	NA	Opt.
Position 8 - Charge pump				
0 = No charge pump	0	Opt.	Std.	Opt.
1 = 6.9 cm ³ /r [.42 in ³ /r] disp. w/1-5/16 - 12 UN-2B SAE O-Ring straight thread inlet port (S)	1	Std.	NA	NA
2 = 13.8 cm ³ /r [.84 in ³ /r] disp. w/1-5/16 - 12 UN-2B SAE O-Ring straight thread inlet port (S)	2	Opt.	NA	Std.
5 = 10.3 cm ³ /r [.63 in ³ /r], with 1 5/16-12 UN-2B SAE O-Ring port for suction inlet (S)				
8 = 17.2 cm ³ /r [1.05 in ³ /r]; with 1 5/16-12 UN - 2B SAE O-Ring port for suction inlet (S)	8	Std.	NA	Std.
9 = 20.7 cm ³ /r [1.26 in ³ /r]; with 1 5/16-12 UN - 2B SAE O-Ring port for suction inlet (S)	9	Std.	NA	Std.

Model code - Single pump

72400 Series

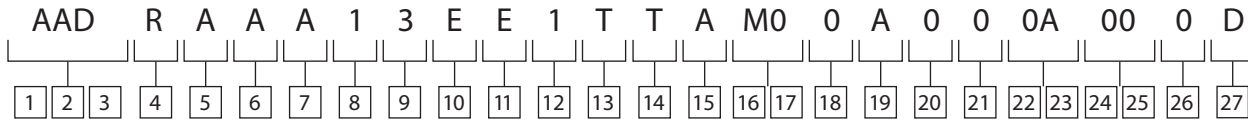

	Code	Single unit	Tandem front	Unit rear
Position 9 - Charge pump relief setting and routing				
0 = No charge pump	0	Opt.	Std.	Opt.
3 = 17- 21 bar [250-300 PSI] (relieved to case)	3	Opt.	NA	Std.
4 = 17- 21 bar [250-300 PSI], 1- 5/16 - 12 UN-2B SAE O-Ring straight thread outlet port (C3), 3/4 - 16 UNF-2B SAE O-Ring straight thread return port (C4), (remote filter and/or heat exchanger, relieved to case)	4	Opt.	NA	Opt.
5 = 20.68-22.41 bar [300-325 lbf/in ²] (relieved to case)	5	Opt.	NA	Opt.
7 = 13.10-15.17 bar [190-220 lbf/in ²] (relieved to case)	7	Opt.	NA	Opt.
A = 10.69-11.38 bar [155-165 lbf/in ²] (relieved to case); 7/8 - 14 UNF-2B SAE O-Ring port for charge pressure – A (C6) – bottom	A	Opt.	NA	Opt.
D = 14.89-16.82 bar [216-244 lbf/in ²] (relieved to case)	D	Opt.	NA	Opt.
Position 10 - Auxiliary port, size and location (left C1 and right C2)				
0 = No auxiliary port	0	Opt.	Opt.	Opt.
A = 750-16 UNF-2B SAE O-Ring port – Left (C1) side (housing)	A	Opt.	Std.	Std.
D = On both sides w/left side plugged (housing), 3/4 - 16 UNF-2B SAE O-Ring straight thread port	D	Opt.	Std.	Std.
E = On both sides and both plugged (housing), 3/4 - 16 UNF-2B SAE O-Ring straight thread port	E	Std.	NA	NA
Position 11 - Drain port size and location (left D1 and right D2)				
D = On both sides w/ right side plugged & rear flange drained into housing, 1-1/16 - 12 UN-2B SAE O-Ring straight thread port	D	Opt.	Opt.	NA
E = On both Sides w/ left side plugged & rear flange drained into housing, 1-1/16 - 12 UN-2B SAE O-Ring straight thread port	E	Std.	Std.	NA
M = On both sides w/ left side plugged & thru drain into mount (front), 1-1/16 - 12 UN-2B SAE O-Ring straight thread port	M	NA	NA	Opt.
Position 12 - Main ports, size and location (port A and B)				
1 = 1- 5/16 - 12 UN-2B O-Ring straight thread port, same side (right side)	1	Std.	Opt.	Opt.
2 = 1- 5/16 - 12 UN-2B O-Ring straight thread port, same side (left side)	2	Opt.	Std.	Std.
6 = 1 1/16 -12 UN-2B SAE O-Ring port (A & B) – right side	6	Opt.	Opt.	Opt.
7 = 1 1/16-12 UN-2B SAE O-Ring port (A & B) – left side	7	Opt.	Opt.	Opt.
8 = M33 X 2 Metric O-Ring port (A & B) – right side	8	Opt.	Opt.	Opt.
9 = M33 X 2 Metric O-Ring port (A & B) – left side	9	Opt.	Opt.	Opt.
A = Dash 12 STC type II+ direct port (A & B) - right side	A	Opt.	Opt.	Opt.
B = Dash 12 STC Type II+ direct port (A & B) - left side	B	Opt.	Opt.	Opt.
Positions 13, 14 - Relief valve setting for main port (select a Setting for port "A" in position 13 and port "B" in Position 14)				
0 = Check valve only	0	Opt.	Opt.	Opt.
B = 140 bar [2000 PSI]	B	Opt.	Opt.	Opt.
E = 175 bar [2500 PSI]	E	Opt.	Opt.	Opt.
H = 210 bar [3000 PSI]	H	Opt.	Opt.	Opt.
L = 240 bar [3500 PSI]	L	Opt.	Opt.	Opt.
N = 275 bar [4000 PSI]	N	Opt.	Opt.	Opt.
Q = 310 bar [4500 PSI]	Q	Opt.	Opt.	Opt.
T = 345 bar [5000 PSI]	T	Std.	Std.	Std.
Position 15 - Additional functions				
0 = No additional functions	0	Std.	Std.	Std.
A = Bypass valve	A	Opt.	Opt.	Opt.
C = Bleed-off valve in port B	C	Opt.	Opt.	Opt.
E = Bypass valve, bleed off valve in port A, 609-10.3 bar [100-150 lbf/in ²]	E	Opt.	Opt.	Opt.

Model code - Single pump

72400 Series

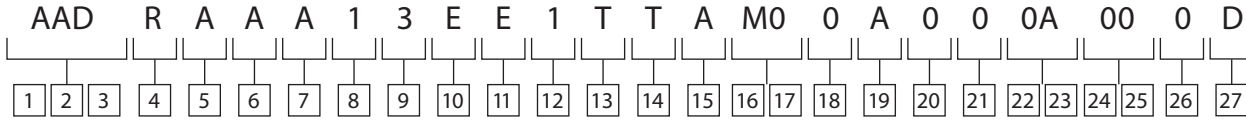

	Code	Single unit	Tandem front	Unit rear
Positions 16, 17 - Pump controls				
Manual control				
M0 = No additional features	M0	Std.	Std.	Std.
MA = Neutral lockout switch (includes wide band neutral)	MA	Opt.	Opt.	Opt.
MB = Neutral detent (Includes Wide Band Neutral)	MB	Opt.	Opt.	Opt.
MC = Wide band neutral	MC	Opt.	Opt.	Opt.
Port plate				
P0 = No additional features	P0	Opt.	Opt.	Opt.
Hydraulic remote control				
HA = 5-15 bar [72-217 PSI] pilot pressure range, 2X Port .4375-20 UNF-2B SAE O-Ring port	HA	Opt.	Opt.	Opt.
Electrohydraulic control				
EC = Electronic Proportional control 12 Vdc without electronic driver	EC	Opt.	Opt.	Opt.
ED = Electronic Proportional control 24 Vdc without electronic driver	ED	Opt.	Opt.	Opt.
EN = Electronic Proportional control 12 volt DC w/o electronic driver with deutsch connector	EE	Opt.	Opt.	Opt.
EP = Electronic Proportional control 12 volt DC w/o electronic driver with deutsch connector with fine Hi-gain control metering	EP	Opt.	Opt.	Opt.
ER = Electronic Proportional control 12 volt DC w/o electronic driver with deutsch connector with weather pack 4 connector, with fine Hi-gain control metering	ER	Opt.	Opt.	Opt.
ES = Electronic Proportional control 24 volt DC w/o electronic driver with deutsch connector	ES	Opt.	Opt.	Opt.
Solenoid operated				
SA = 3 pos (FNR) 12 Vdc solenoids with weather pack connectors (locations at port s1 and s2)	SA	Opt.	Opt.	Opt.
SB = 2 pos 12 Vdc solenoid with weather pack connectors (location at port s1)	SB	Opt.	Opt.	Opt.
SC = 2 pos 12 Vdc solenoid with weather pack connectors (location at port s2)	SC	Opt.	Opt.	Opt.
SK = Proportion solenoid control 12V with non-contact swash feedback sensor with 4-Pin metripack connector	SK	Std.	Std.	Std.
Position 18 - Destroke valve				
0 = Not required	0	Std.	Std.	Std.
1 = With 12 VDC coil and weather pack connector	1	Opt.	Opt.	Opt.
2 = With 24 VDC coil and weather pack cConnector	2	Opt.	Opt.	Opt.
3 = With 12 VDC coil and DIN 43650 connector	3	Opt.	Opt.	Opt.
4 = With 24 VDC coil and DIN 43650 connector	4	Opt.	Opt.	Opt.
7 = De-stroke valve with integrated deutsch connector (normally closed)	7	Opt.	Opt.	Opt.
Position 19 - Supply orifice (location p)				
0 = No supply orifice (NA for pumps w/ destroke)	0	Opt.	Opt.	Opt.
A = 0.71 mm [.028 in]	A	Opt.	Opt.	Opt.
B = 0.81 mm [.032 in]	B	Opt.	Opt.	Opt.
C = 0.91 mm [.036 in]	C	Std.	Std.	Std.
D = 1.02 mm [.040 in]	D	Opt.	Opt.	Opt.
E = 1.12 mm [.044 in]	E	Opt.	Opt.	Opt.
F = 1.32 mm [.052 in] (maximum orifice size if position 18 selection is 1 thru 4)	F	Opt.	Opt.	Opt.
G = 1.45 mm [.057 in] (NA for pumps w/ destroke)	G	Opt.	Opt.	Opt.
H = 1.65 mm [.065 in] (NA for pumps w/ destroke)	H	Opt.	Opt.	Opt.
J = 1.85 mm [.073 in] (NA for pumps w/ destroke)	J	Opt.	Opt.	Opt.

Model code - Single pump

72400 Series

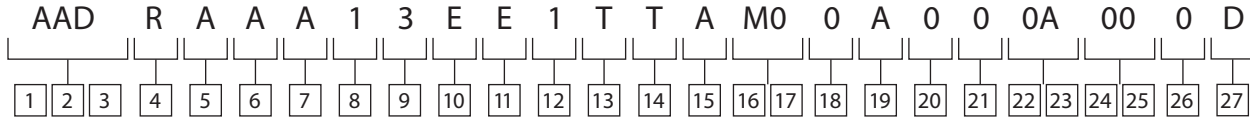

	Code	Single unit	Tandem front	Unit rear
Position 20 - Control orifice (location s1 & s2)				
0 = No control orifice	0	Std.	Std.	Std.
A = 0.71 mm [.028 in]	A	Opt.	Opt.	Opt.
B = 0.81 mm [.032 in]	B	Opt.	Opt.	Opt.
C = 0.91 mm [.036 in]	C	Opt.	Opt.	Opt.
D = 1.02 mm [.040 in]	D	Opt.	Opt.	Opt.
E = 1.12 mm [.044 in]	E	Opt.	Opt.	Opt.
F = 1.32 mm [.052 in]	F	Opt.	Opt.	Opt.
G = 1.45 mm [.057 in]	G	Opt.	Opt.	Opt.
Position 21 - Special control option				
Manual control (only)				
0 = No special control options (standard control lever position)	0	Std.	Std.	Std.
Positions 22, 23 - Paint				
0A = Primer	0A	Std.	Std.	Std.
0B = Black	0B	Opt.	Opt.	Opt.
Positions 24, 25 - Special features				
00 = No special features	00	Std.	Std.	Std.
BB = Adjustable displacement limiter, both sides	BB	Opt.	Opt.	Opt.
CK = Speed sensor
Position 26 - Identification				
0 = Standard	0	Std.	Std.	Std.
Position 27 - Design code				
D = Danfoss - assigned design code				

Model code - Back to Back pumps

70360 Series

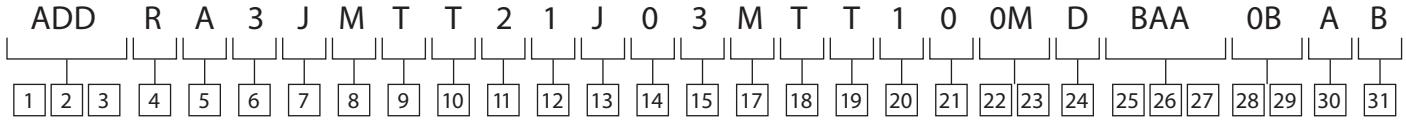

ADD - Series 70360 Back to Back manually variable displacement axial piston pump with SAE J744 flange 101-2 (2 Bolt B)

All left (CCW) or right (CW) directions given are viewed from the input shaft end of the pump

	Code
Position 4 - Input shaft rotation	
L = Left hand rotation (CCW)	L
R = Right hand rotation (CW)	R
Position 5 - Input shaft	
A = 15 tooth external spline, 16/32 pitch, 24.981 [.9835] major diameter; 46 [1.81] shaft ext.	A
B = 41 tooth external spline, 48/96 pitch, 22.225 [.875] major diameter; 24.4 [.96] shaft ext.	B
C = 13 tooth external spline, 16/32 pitch, 21.806 [.858] major diameter; 41.2 [1.62] shaft ext.	C
D = .125:1 taper, 25.4 [1.000] Dia., 6.38 [.251] W X 19.8 [.78] L keyway, .375-24 UNF-2B thread; 35.1 [1.38] shaft extension	D
Position 6 - Displacement & rotating kit- front	
1 = 40.6 cm ³ /r [2.48 in ³ /r]; rotating kit- standard	1
3 = 49.2 cm ³ /r [3.00 in ³ /r]; rotating kit- standard	3
6 = 35.1 cm ³ /r [2.10 in ³ /r]; rotating kit- standard	6
7 = 37.7 cm ³ /r [2.30 in ³ /r]; rotating kit- standard	7
9 = 27.9 cm ³ /r [1.70 in ³ /r]; rotating kit- standard	9
B = 45.7 cm ³ /r [2.79 in ³ /r]; rotating kit- high strength	B
Position 7 - Valve plate- front	
A = Type -1 (standard)	A
Position 8 - Control shaft- front	
C = Right; 25.27-25.35 [.995-.998] diameter straight shaft with 9.47-9.73 [.373-.383] Dia. hole; 128 [5.04] from centerline to control shaft end	C
D = Left; 25.27-25.35 [.995-.998] diameter straight shaft with 9.47-9.73 [.373-.383] Dia. hole; 128 [5.04] from centerline to control shaft end	D
M = Left; 19.1 [.75] square shaft with bolt groove; 134.1 [5.28] from centerline to control shaft end	M
N = Right; 19.1 [.75] square shaft with bolt groove; 121.7 [4.79] from centerline to control shaft end	N
R = Left; 19.1 [.75] square shaft without bolt groove; 128 [5.04] from centerline to control shaft end	R
T = Left; 25.27-25.35 [.995-.998] diameter straight shaft with 6.27-6.35 [.247-.250] W X 19 [.75] L Key; 128 [5.04] from centerline to control shaft end; .375-24 Unf-2b thread; 15.2 [.60] minimum full thread	T
Position 9 - Relief setting for main port- A front	
0 = Check valve only	0
B = 137.9 bar [2000 lbf/in ²]	B
E = 172.4 bar [2500 lbf/in ²]	E
H = 206.8 bar [3000 lbf/in ²]	H
L = 241.3 bar [3500 lbf/in ²]	L
N = 275.8 bar [4000 lbf/in ²]	N
Q = 310.3 bar [4500 lbf/in ²]	Q
T = 344.7 bar [5000 lbf/in ²]	T
Position 10 - Relief setting for main port- B front	
0 = Check valve only	0
B = 137.9 bar [2000 lbf/in ²]	B
E = 172.4 bar [2500 lbf/in ²]	E
H = 206.8 bar [3000 lbf/in ²]	H
L = 241.3 bar [3500 lbf/in ²]	L
N = 275.8 bar [4000 lbf/in ²]	N
Q = 310.3 bar [4500 lbf/in ²]	Q
T = 344.7 bar [5000 lbf/in ²]	T
Position 11 - Drain Port size and location- front	
1 = 2x .750-16 UNF-2B SAE O-Ring port, top (D1); bottom, front plugged (D2)	1
2 = 2X .750-16 UNF-2B SAE O-Ring port, top, plugged (D1); bottom (D2)	2

Model code - Back to Back pumps

70360 Series

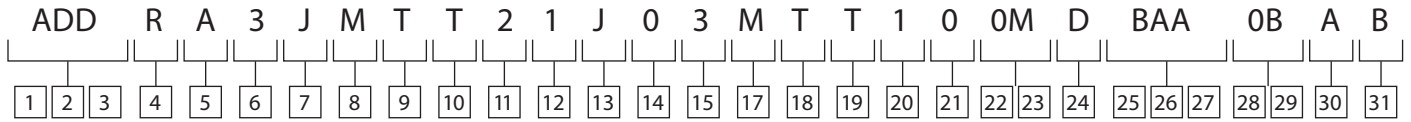

	Code
3 = 2x .750-16 UNF-2B SAE O-Ring port, top, plugged (D1); bottom, plugged (D2);	3
4 = 2x .750-16 UNF-2B SAE O-Ring port, top (D1); Bottom (D2)	4
5 = 2x 1.0625-12 UNF-2B SAE O-Ring ports, top plugged (D1); bottom (D2)	5
6 = 2x 1.0625-12 UNF-2B SAE O-Ring ports, top (D1); bottom plugged (D2)	6
Position 12 - Main ports (A & B)	
1 = 4x 1.0625-12 UN-2B SAE O-Ring ports; front ports top, rear ports bottom	1
2 = 4x 1.0625-12 UN-2B SAE O-Ring ports; front ports bottom, rear ports top	2
Position 13 - Auxiliary port and bypass valve	
B = 2X .750-16 UNF-2B SAE O-Ring port, top plugged (C1), bottom (C2), no bypass valve	B
D = 2X .750-16 UNF-2B SAE O-Ring port, top (C1); bottom (C2); no bypass valve	D
J = 4X .750-16 UNF-2B SAE O-Ring port, 2x top 2 plugged (C1); 2x bottom 1 plugged (C2); dump valve port open, no bypass valve	J
Position 14 - Charge relief setting and routing	
0 = None	0
1 = 4.14-7.59 bar [60-110 lbf/in ²]; relieved to case	1
2 = 6.89-10.34 bar [100-150 lbf/in ²]; relieved to case	2
3 = 10.34-13.79 bar [150-200 lbf/in ²]; relieved to case	3
4 = 13.79-17.24 bar [200-250 lbf/in ²]; relieved to case	4
5 = 20.69-24.14 bar [300-350 lbf/in ²]; relieved to case	5
6 = 24.13-27.58 bar [350-400 lbf/in ²]; relieved to case	6
Position 15 - Displacement & rotating kit - rear	
1 = 40.6 cm ³ /r [2.48 in ³ /r]; rotating kit- standard	1
3 = 49.2 cm ³ /r [3.00 in ³ /r]; rotating kit- standard	3
6 = 35.1 cm ³ /r [2.10 in ³ /r]; rotating kit- standard	6
7 = 37.7 cm ³ /r [2.30 in ³ /r]; rotating kit- standard	7
9 = 27.9 cm ³ /r [1.70 in ³ /r]; rotating kit- standard	9
B = 45.7 cm ³ /r [2.79 in ³ /r]; rotating kit- high strength	B
Position 16 - Valve plate - rear	
A = Type -1 (standard)	A
Position 17 - Control Shaft - rear	
C = Right; 25.27-25.35 [.995-.998] diameter straight shaft with 9.47-9.73 [.373-.383] Dia. hole; 128 [5.04] from centerline to control shaft end	C
D = Left; 25.27-25.35 [.995-.998] diameter straight shaft with 9.47-9.73 [.373-.383] Dia. hole; 128 [5.04] from centerline to control shaft end	D
M = Left; 19.1 [.75] square shaft with bolt groove; 134.1 [5.28] from centerline to control shaft end	M
N = Right; 19.1 [.75] square shaft with bolt groove; 121.7 [4.79] from centerline to control shaft end	N
R = Left; 19.1 [.75] square shaft without bolt groove; 128 [5.04] from centerline to control shaft end	R
T = Left; 25.27-25.35 [.995-.998] diameter straight shaft with 6.27-6.35 [.247-.250] W X 19 [.75] L Key; 128 [5.04] from centerline to control shaft end; .375-24 Unf-2b thread; 15.2 [.60] minimum full thread	T
Position 18 - Relief setting for main port - A rear	
0 = Check valve only	0
B = 137.9 bar [2000 lbf/in ²]	B
E = 172.4 bar [2500 lbf/in ²]	E
H = 206.8 bar [3000 lbf/in ²]	H
L = 241.3 bar [3500 lbf/in ²]	L
N = 275.8 bar [4000 lbf/in ²]	N
Q = 310.3 bar [4500 lbf/in ²]	Q
T = 344.7 bar [5000 lbf/in ²]	T
Position 19 - Relief setting for main port- B rear	
0 = Check valve only	0
B = 137.9 bar [2000 lbf/in ²]	B
E = 172.4 bar [2500 lbf/in ²]	E

Model code - Back to Back pumps

70360 Series

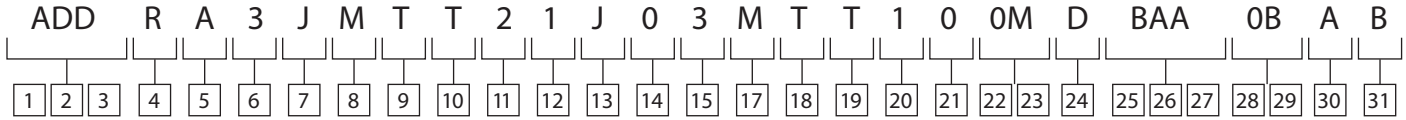

	Code
H = 206.8 bar [3000 lbf/in]	H
L = 241.3 bar [3500 lbf/in]	L
N = 275.8 bar [4000 lbf/in]	N
Q = 310.3 bar [4500 lbf/in]	Q
T = 344.7 bar [5000 lbf/in]	T
Position 20 - Drain port size and location- rear	
1 = 2x .750-16 UNF-2B SAE O-Ring port, top (D3); bottom plugged (D4)	1
2 = 2X .750-16 UNF-2B SAE O-Ring port, top, plugged (D3); bottom (D4)	2
3 = 2x .750-16 UNF-2B SAE O-Ring port, top, plugged (D3); bottom, plugged (D4);	3
4 = 2x .750-16 UNF-2B SAE O-Ring port, top (D3); bottom (D4)	4
5 = 2x 1.0625-12 UNF-2B SAE O-Ring ports, top plugged (D3); bottom (D4)	5
Position 21 - Additional functions	
0 = None	0
Position 22, 23 - Special fetures	
00 = None	00
0D = Mounting holes, 4x .375-16 UNC-2B thd, 15.2 [.60] min full thd, 50.8 [2.0] between Mtg holes	0D
0L = Mounting holes, 4x .375-16 UNC-2B thd,, 15.2 [.60] min full thd, 50.8 [2.0] between Mtg holes; increased torque rating for aux pump; fluorocarbon drive shaft seal	0L
0M = Mounting holes, 2x .375-16 UNC-2B thd, 15.2 [.60] min full thd, right side, 50.8 [2.0] between Mtg holes; 2x .375-16 UNC-2A, stud bolt, 12.7 [.50] long, left side; gear pump break in at 227.5 Bar [3300]lbf/in	0M
0T = Mounting holes, 2x .375-16 UNC-2B thd, 15.2 [.60] min full thd, right side, 50.8 [2.0] between Mtg holes; 2x .375-16 UNC-2A stud bolt, 12.7 [.50] long, left side; gear pump break in at 227.5 Bar [3300]lbf/in; special control shaft seal	0T
0Y = Mounting holes, 4x .375-16 UNC-2B thd, 15.2 [.60] min full thd, right side, 50.8 [2.0] between Mtg holes; 2x .375-16 UNC-2A stud bolt, 12.7 [.50] long, left side; special control shaft seal, special bolts w/loctite	0Y
AB = Mounting holes, 4x .375-16 UNC-2B Thd, 15.2 [.60] min full thd, right side, 50.8 [2.0] between Mtg holes; 2x .375-16 UNC-2A stud bolt, 12.7 [.50] long, left side; special control shaft seal, spl bolts w/loctite; high strength rotating kit	AB
Position 24 Auxiliary mount features	
0 = None	0
C = Integral mount series "26" (RH rotation suction port bottom / LH rotation suction port top) with 11 tooth input	C
D = Integral mount series "27" (RH rotation suction port bottom / LH rotation suction port top)	D
E = Integral mount series "26" (RH rotation suction port bottom / LH rotation suction port top) with 35 tooth input	E
F = 2 Bolt-B SAE flange series 101-2 with 13 tooth 16/32 internal spline shaft accepts shaft extension 41.1 [1.62]	F
G = 2 Bolt-A SAE flange series 101-2 with 11 tooth 16/32 internal spline shaft accepts shaft extension 31.5 [1.24]	G
Position 25, 26, 27 - Auxiliary pump number	
0 = None	0
C = Integral mount series "26" (RH rotation suction port bottom/ LH rotation suction port top) w/ 11 tooth input	C
D = Integral mount series "27" (RH rotation suction port bottom / LH rotation suction port top)	D
E = Integral mount series "26" (RH rotation suction port bottom / LH rotation suction port top) w/ 35 tooth input	E
F = [2 Bolt B] SAE flange series 101-2 with 13 tooth 16/32 internal spline shaft accepts shaft extension 41.1 [1.62]	F
G = [2 Bolt A] SAE flange series 101-2 with 11 tooth 16/32 internal spline shaft accepts shaft extension 31.5 [1.24]	G
Position 28, 29 - Paint	
00 = None	00
0B = Black per spec 209-13B	0B
CD = Blue primer per spec 209-13CD	CD
0P = Gray per spec 209-13P	0P
CF = Bright yellow per spec 209-13CF	CF
Position 30 - Identification	
0 = Standard	0
Position 31 - Design code B	
	B

Model code - Back to Back pumps

72400 Series

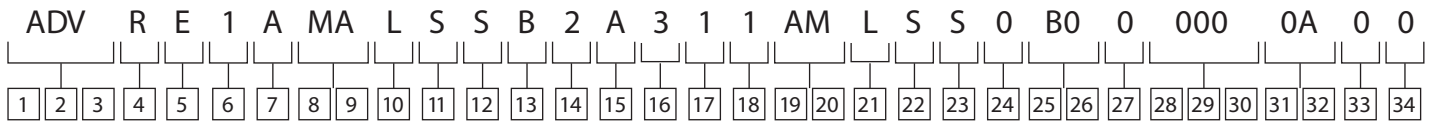

ADV - Series 72400 Back to Back servo controlled variable displacement axial piston pump with SAE J744 flange 101-2 (2 Bolt B)

All left (CCW) or right (CW) directions given are viewed from the input shaft end of the pump

		Code
Position 4 - Input shaft rotation		
L	= Left hand rotation (CCW)	L
R	= Right hand rotation (CW)	R
Position 5 - Input shaft		
A	= 15 tooth external spline, 16/32 pitch, 24.981 [.983] major diameter; 46 [1.81] shaft ext.	A
B	= 41 tooth external spline, 48/96 pitch, 22.225 [.875] major diameter; 24.4 [.96] shaft ext.	B
C	= 13 tooth external spline, 16/32 pitch, 21.806 [.858] major diameter; 41.2 [1.62] shaft ext.	C
D	= .125:1 taper, 25.4 [1.000] diameter, 6.38 [.251] W X 19.8 [.78] L keyway, .375-24 UNF-2B thread; 35.1 [1.38] shaft ext.	D
E	= 15 tooth external spline, 16/32 pitch, 24.981 [.983] major diameter; 57.4 [2.26] shaft ext.	E
Position 6 - Displacement & rotating kit- front		
1	= 40.6 cm ³ /r [2.48in ³ /r]; rotating kit- standard	1
2	= 49.2 cm ³ /r [3.00in ³ /r]; rotating kit- standard	2
3	= 49.2 cm ³ /r [3.00in ³ /r]; rotating kit- high pressure	3
Position 7 - Valve plate- front		
A	= Type -1 (standard)	A
Position 8, 9 - Control assembly- front		
HA	Hydraulic remote with 5-15 bar [72-217.7 lbf/in ²] pressure range, 2x .4375-20 UNF-2B SAE O-Ring ports; external supply port (P) - .4375-20 UNF-2B SAE O-Ring port	HA
ML	Manual control, high gain, shortened input control shaft (+/- 17 degree active control shaft rotation) with control handle and key; .750-16 UNF-2B SAE O-Ring port - plugged; external supply port (P) - .4375-20 UNF-2B SAE O-Ring port	ML
SF	Proportional solenoid control 12 volt Dc with non-contact feedback sensor with 3 pin metri-pack connector; external supply port (P) - .5625-16 UNF-2B SAE O-Ring port	SF
Position 10 - Relief setting for main port- A front		
0	= Check valve only	0
C	= 137.9 bar [2000 lbf/in ²]	C
E	= 172.4 bar [2500 lbf/in ²]	E
H	= 224.1 bar [3250 lbf/in ²]	H
L	= 275.8 bar [4000 lbf/in ²]	L
N	= 310.3 bar [4500 lbf/in ²]	N
R	= 344.7 bar [5000 lbf/in ²]	R
Position 11 - Relief setting for main port - B front		
0	= Check valve only	0
C	= 137.9 bar [2000 lbf/in ²]	C
E	= 172.4 bar [2500 lbf/in ²]	E
H	= 224.1 bar [3250 lbf/in ²]	H
L	= 275.8 bar [4000 lbf/in ²]	L
N	= 310.3 bar [4500 lbf/in ²]	N
R	= 344.7 bar [5000 lbf/in ²]	R
Position 12 - Drain port size and location - front		
0	= None	0
A	= 1.0625-12 UN-2B SAE O-Ring port - left side housing (D1)	A
B	= 1.0625-12 UN-2B SAE O-Ring port - right side housing (D2)	B
Position 13 - Main ports (A & B)		
1	= 4x 1.0625-12 UN-2B SAE O-Ring ports; front ports left, rear ports right	1
2	= 4x 1.0625-12 UN-2B SAE O-Ring ports; front ports right, rear ports left	2

Model code - Back to Back pumps

72400 Series

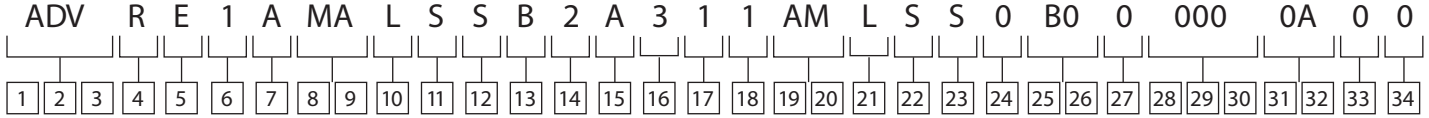

		Code
Position 14 - Auxiliary port and bypass valve		
0	= .750-16 UN-2B SAE O-Ring ports - left (C1) and right (C2) sides; no bypass valve	0
A	= .750-16 UN-2B SAE O-Ring ports - left (C1) and right (C2) sides, right side plugged; no bypass valve	A
B	= .750-16 UN-2B SAE O-Ring ports - left (C1) and right (C2) sides, left side plugged; no bypass valve	B
C	= .750-16 UN-2B SAE O-Ring ports - left (C1) and right (C2) sides, right side plugged; bypass valve front and rear	C
D	= .750-16 UN-2B SAE O-Ring ports - left (C1) and right (C2) sides, left side plugged; bypass valve front and rear	D
Position 15 - Charge pump		
0	= No charge pump	0
1	= 13.8 cm ³ /r [.84 in ³ /r] with 1.3125-12 UN-2B SAE O-Ring port for suction inlet (S); charge pressure discharge port (C3) - .750-16 UN-2B SAE O-Ring port	1
2	= 17.2 cm ³ /r [1.05 in ³ /r] with 1.3125-12 UN-2B SAE O-Ring port for suction inlet (S); charge pressure discharge port (C3) - .750-16 UN-2B SAE O-Ring port	2
3	= 20.7 cm ³ /r [1.26 in ³ /r] with 1.3125-12 UN-2B SAE O-Ring port for suction inlet (S); charge pressure discharge port (C3) - .750-16 UN-2B SAE O-Ring port	3
Position 16 - Charge relief setting and routing		
0	= No charge pump	0
1	= 17.24-20.68 bar [250-300 lbf/in ²] relieved to case	1
Position 17 - Displacement & rotating kit - rear		
1	= 40.6 cm ³ /r [2.48 in ³ /r]; rotating kit- standard	1
2	= 49.2 cm ³ /r [3.00 in ³ /r]; rotating kit- standard	2
3	= 49.2 cm ³ /r [3.00 in ³ /r]; rotating kit- high pressure	3
Position 18 - Valve plate - rear		
A	= Type -1 (standard)	A
Position 19, 20 - Control assembly - rear		
HA	= Hydraulic remote with 5-15 Bar [72-217 lbf/in ²] pilot pressure range, 2x .4375-20 UNF-2B SAE O-Ring ports; external supply port (P) - .4375-20 UNF-2B SAE O-Ring port	HA
ML	= Manual control, high gain, shortened input control shaft (+/- 17 degree active control shaft rotation) with control handle and key; .750-16 UNF-2B SAE O-Ring port - plugged; external supply port (P) - .4375-20 UNF-2B SAE O-Ring port	ML
SF	= Proportional solenoid control 12 Volt Dc with non-contact feedback sensor with 3 pin metri-pack connector; external supply port (P) - .5625-18 UNF-2B SAE O-Ring port	SF
Position 21 - Relief setting for main port - A rear		
0	= Check valve only	0
C	= 137.9 bar [2000 lbf/in ²]	C
E	= 172.4 bar [2500 lbf/in ²]	E
H	= 224.1 bar [3250 lbf/in ²]	H
L	= 275.8 bar [4000 lbf/in ²]	L
N	= 310.3 bar [4500 lbf/in ²]	N
R	= 344.7 bar [5000 lbf/in ²]	R
Position 22 - Relief setting for main port - B rear		
0	= Check valve only	0
C	= 137.9 bar [2000 lbf/in ²]	C
E	= 172.4 bar [2500 lbf/in ²]	E
H	= 224.1 bar [3250 lbf/in ²]	H
L	= 275.8 bar [4000 lbf/in ²]	L
N	= 310.3 bar [4500 lbf/in ²]	N
R	= 344.7 bar [5000 lbf/in ²]	R
Position 23 - Drain port size and location- rear		
0	= None	0
A	= 1.0625-12 UN-2B SAE O-Ring port - left side housing (D1)	A
B	= 1.0625-12 UN-2B SAE O-Ring port - right side housing (D2)	B

Model code - Back to Back pumps

72400 Series

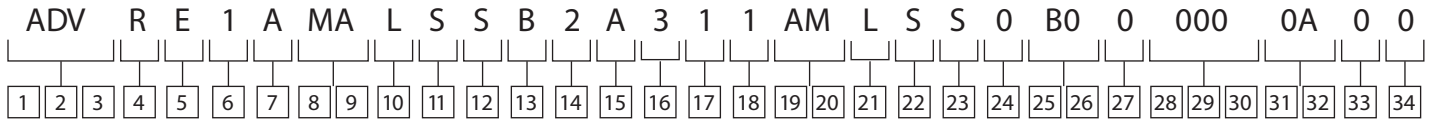

	Code
Position 24 - Additional functions	
0 = None	0
A = Speed sensor with sensor adapter in rear housing	A
B = Diameter 1.60 [.063] orifice (S1 & S2)	B
Position 25, 26 - Special features	
00 = None	00
0A = Adj servo stop, both sides; port setting all ports A1, A2, B1, B2 - 46.0 [1.61] in ³ /r (36 gpm) at 2800 rpm; Mtg holes-2x M10 X 1.5-6h rear Hsg; Mtg holes-2x M10 X 1.5-6h centre manifold	0A
0B = Adj servo stop, both sides; port setting all ports A1, A2, B1, B2 - 40.2 [1.48] in ³ /r (32 gpm) at 3000 rpm (full flow); Mtg holes-2x M10 X 1.5-6h rear Hsg; Mtg holes-2x M10 X 1.5-6h center manifold	0B
0C = Adj servo stop, both sides; port setting all ports A1, A2, B1, B2 - 46.0 [1.61] in ³ /r (36 gpm) at 2800 rpm; Mtg Holes-2x M10 X 1.5-6h rear Hsg; Mtg holes-2x M10 X 1.5-6h centre manifold	0C
0D = Mounting holes-2x M10 X 1.5-6h rear Hsg; mounting holes-2x M10 X 1.5-6h center manifold	0D
0E = Adj servo stop, both sides; port setting A1, B2 - 39.8 [1.40] in ³ /r (30-31.2 gpm) & A2, B1 - 40.6 [1.48] in ³ /r (32 gpm) at 3000 rpm; Mtg holes-2x M10 X 1.5-6h rear Hsg; Mtg holes-2x M10 X 1.5-6h centre manifold	0E
0F = Adj servo stop, both sides; port setting A1, B2 - 35.6 [1.27] in ³ /r (27.1-28.2 gpm) & A2, B1 - 40.6 [1.48] in ³ /r (32 gpm) at 3000 rpm; Mtg holes-2x M10 X 1.5-6h rear Hsg; Mtg holes-2x M10 X 1.5-6h centre manifold	0F
0G = Adj servo stop, both sides; port setting all ports A1, A2, B1, B2 - 39.8 [1.40] in ³ /r (32 gpm) at 3000 rpm; Mtg holes-2x M10 X 1.5-6h rear Hsg; Mtg holes-2x M10 X 1.5-6h centre manifold and improved teflon bushing material	0G
0H = Adj servo stop, both sides; port setting all ports A1, A2, B1, B2 - 46.2 [1.65] in ³ /r (34.5 gpm) at 2800 rpm; Mtg holes-2x M10 X 1.5-6h rear Hsg; Mtg holes-2x M10 X 1.5-6h centre manifold, improved teflon	0H
Position 27 - Auxiliary mount features	
0 = None	0
A = Dual SAE J744 flange 101-2 (2-Bolt B) accepts 13 tooth 16/32 pitch spline with 41.2 [1.62] shaft extension (no coupler required)	A
Position 28, 29, 30 - Auxiliary pump number	
000 = No auxiliary pump	000
AAA = 27003-RBA single gear pump series "27"; displacement 29.5 [1.00] in ³ /r; suction port 1.625-12 UN-2B SAE O-Ring port; pressure port .875-14 UN-2B SAE O-Ring port - sides	AAA
AAB = 27004-RBA single gear pump series "27"; displacement 33.6 [1.05] in ³ /r; suction port 1.625-12 UN-2B SAE O-Ring port; pressure port .875-14 UN-2B SAE O-Ring port -sides	AAB
AAC = 26011-RAL single gear pump series "26"; displacement 27.7 [1.09] in ³ /r; suction port 1.625-12 UN-2B SAE O-Ring port - sides; pressure port .875-14 UN-2B SAE O-Ring port - rear	AAC
AAD = 25502-RAH single gear pump series "L2"; displacement 29.1 [1.08] in ³ /r; suction port 1.625-12 UN-2B SAE O-Ring port; pressure port 1.0625-12 UN-2B SAE O-Ring port - side ports W. suction port on right side	AAD
AAE = 25502-RAH single gear pump series "L2"; displacement 29.1 [1.08] in ³ /r; suction port 1.625-12 UN-2B SAE O-Ring port; pressure port 1.0625-12 UN-2B SAE O-Ring port - side ports W. suction port on left side	AAE
Position 31, 32 - Paint	
00 = None	00
0A = Red oxide primer per spec 209-13A	0A
0B = Black per spec 209-13B	0B
CD = Blue primer per spec 209-13CD	CD
BF = Yellow per spec 209-13BF	BF
Position 33 - Identification	
0 = Standard	0

Hydraulic circuits

Single pumps

70160/70360

Schematic for direct manual controlled pump with integral charge pump, bypass valve and auxiliary ports

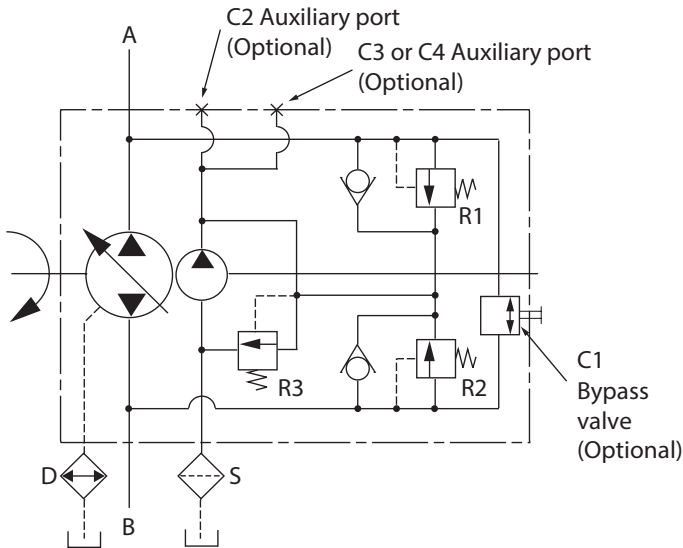

72400

Schematic for servo controlled pump with Electronic proportional control, bypass valve, charge pump and auxiliary ports.

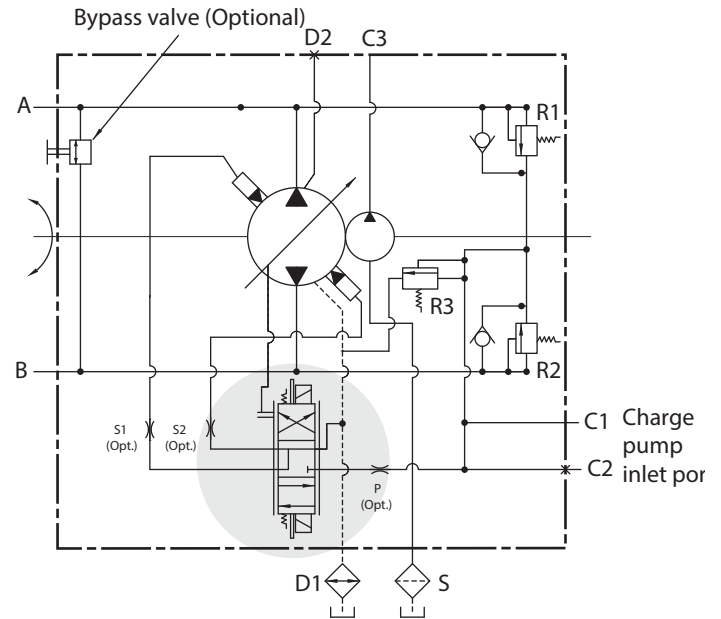

A, B	Main pressure ports
C1, C2, C3	Auxiliary ports
D1, D2	Drain ports
P	Control supply orifice (optional)

R1, R2	High pressure relief valves
R3	Charge/low pressure relief valve
S1, S2	Control servo orifice (optional)

Multiple pumps

Tandem pumps

Two or more piston pumps mounted in series (one behind the other) are called as tandem pumps. The first pump is called as front of tandem & second pump as rear of tandem. These pumps can be used as single pumps in isolation with necessary mounting / shaft interface. Auxiliary piston / gear pumps can be added as per requirement

Back to Back pumps

When two piston pumps are mounted such that their rotating kits are facing each other, such arrangement is called as back to back arrangement. These pumps share same center manifold which includes the flow paths and high pressure ports for both front and rear pump. Back to back pumps works as a single unit and front / rear pump cannot be separated. Auxiliary piston / gear pumps can be added as per requirement.



70360



72400



70360



72400

Hydraulic circuits

70360 Tandem/Back to Back

Schematic for direct manual controlled pump with bypass valve, auxiliary port & without charge pump.

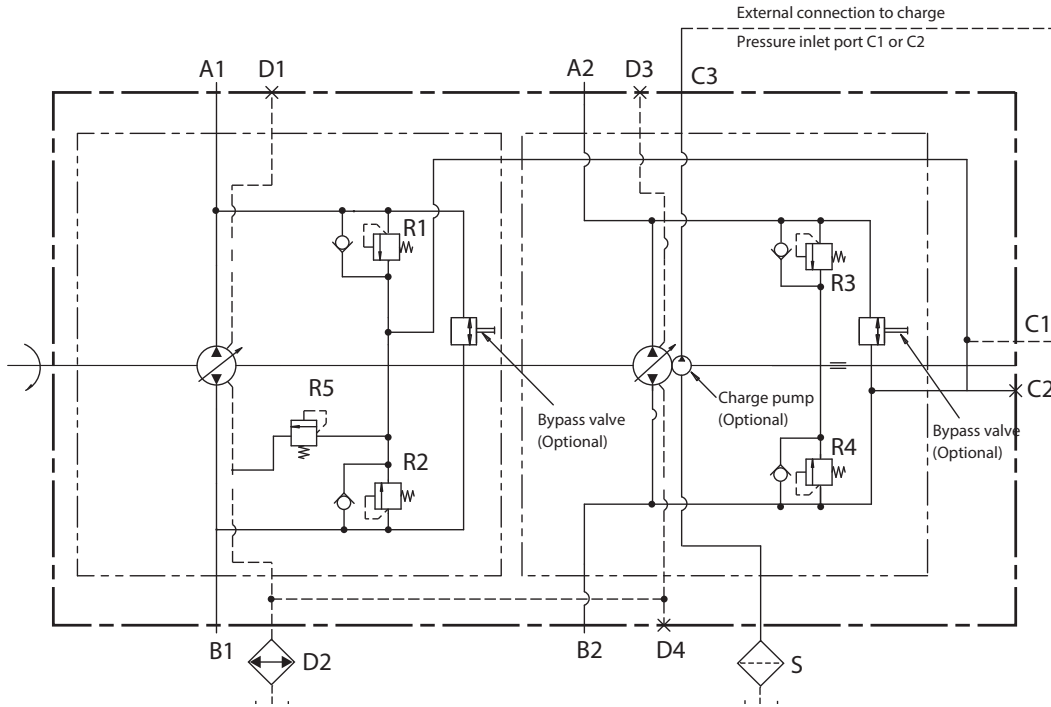

A1, A2, B1, B2	Main pressure ports
C1, C2, C3, C4	Auxiliary ports
D1, D2, D3, D4	Drain ports
P	Control supply orifice (optional)
P1	Pilot pressure front pump
P2	Pilot pressure rear pump
R1, R2, R3, R4	High pressure relief valves
R5	Charge/low pressure relief valve
S1, S2	Control servo orifice (optional)

72400 Tandem/Back to Back

Schematic for servo controlled pump with electronic proportional control, charge pump, auxiliary ports & bypass valve.

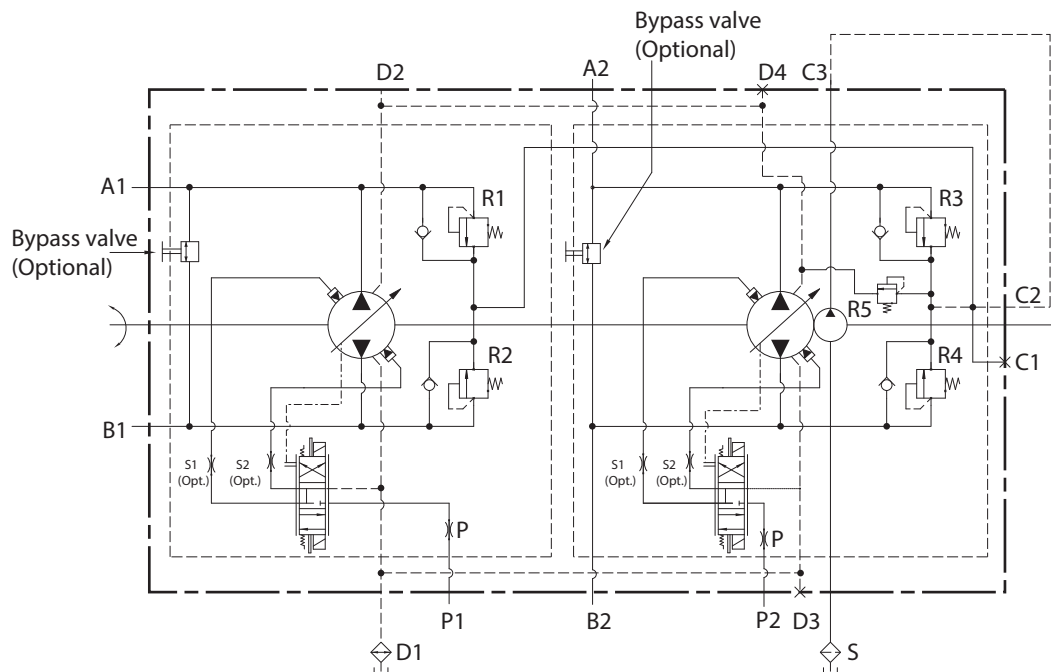

Pump controls

72400 Servo controlled pump

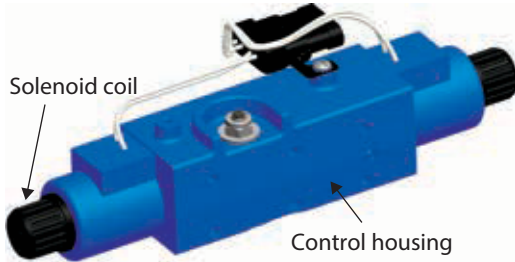

Electronic prop. control (EP/ER)

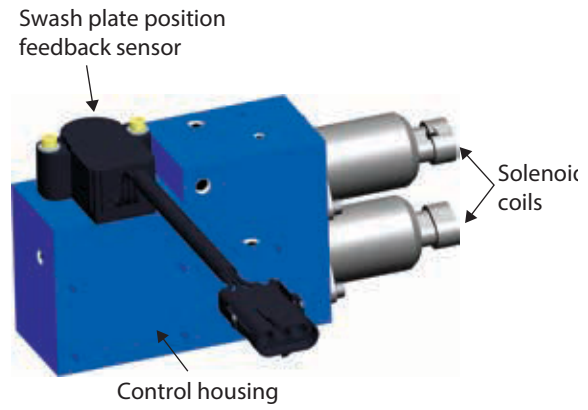

Solenoid control (SK)

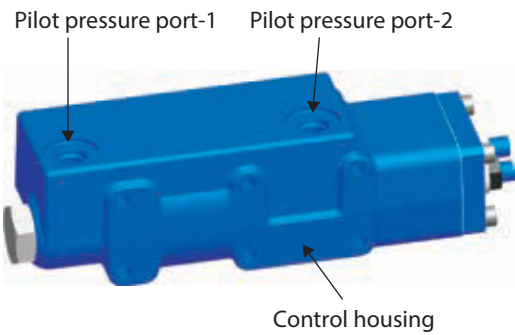

Hydraulic pilot control (HA)

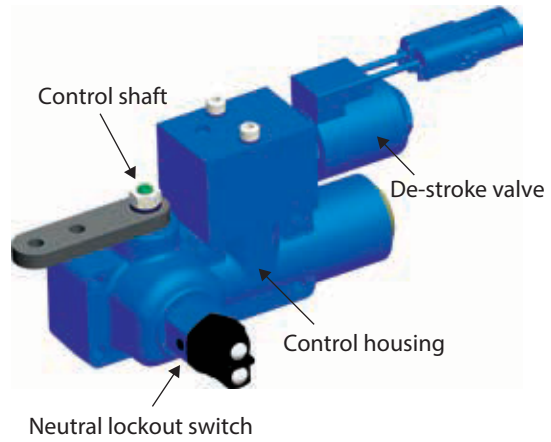

Manual control (MF)

Electronic Proportional displacement control

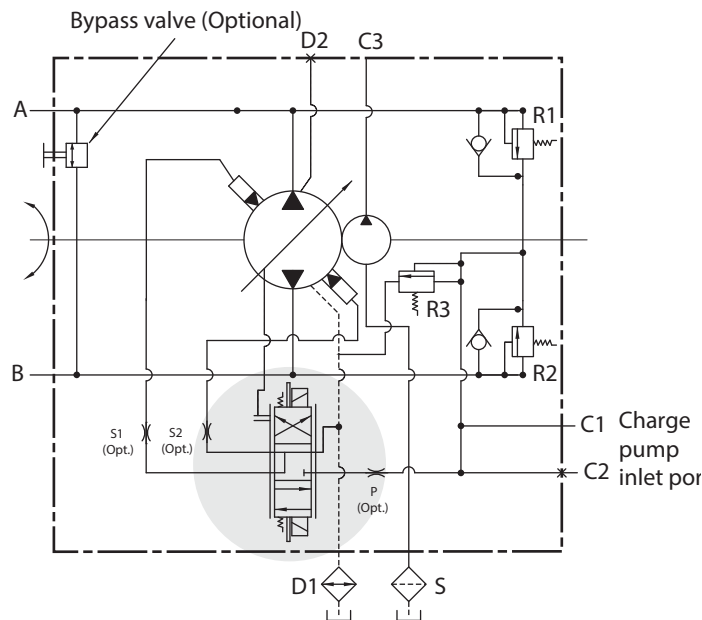

The Electronic Proportional (EP) displacement control is ideal for applications requiring electronic pump displacement control. The EP displacement control provides the flexibility of three command input choices. Control components include a proportional solenoid actuated valve assembly and an electronic solenoid driver module mounted on the pump.

The EP displacement control has been designed to withstand the rigors of off-highway equipment environmental conditions.

EP displacement control features

- Ease of installation
- Automotive style environmentally sealed Metri-pack connectors
- Operates from 12 or 24 Vdc power supply
- External fuse (customer supplied): 3A for 12 Vdc system, 1A for 24 Vdc system
- Three choices for command input signal
- Operating temperature range -40° C to +85° C
- Closed loop current control compensates for resistance change of the proportional solenoids due to temperature variations
- Return to neutral for loss of power, or loss of command input signal
- Mechanical feedback of swashplate position for closed loop control
- External neutral adjustment
- Manual override capability
- SAE J1455 - Recommended environmental practices for electronic equipment design
 - Humidity/temperature extreme cycling
 - Salt spray
 - Splash & Immersion
 - Steam cleaning/high pressure wash
 - Vibration
 - Mechanical shock
 - Temperature cycling
 - Load dump transients
 - Inductive load switching transients
- SAE J1113 - Electromagnetic susceptibility measurement procedures for vehicle components
 - EMI/EMC - Conducted & radiated immunity
- CISPR 25 - International electrotechnical commission "Limits and methods of measurement of radio disturbance characteristics for the protection of receivers used on board vehicles."
 - EMI /EMC - Conducted & radiated emissions

Model Code Option	Description	Command Input Signal	Coil resistance @ room Temperature (Ω)	Inductance* (mH)	Rated continuous Current A	Typical Input Devices
EC	EP control w/o electronic driver	12V	5.19± 0.52	7.0± 1.0	1.5	Requires customer supplied electronics
ED	EP control w/o electronic driver	24V	20.8 ± 2.08	27.7 ± 3.0	0.75	
EN	EP control w/o electronic driver, w/ deutsch connector	12V	5.19± 0.52	7.0± 1.0	1.5	
EP	EP control w/o electronic driver, w/ deutsch connector & 2V fine high gain control metering	12V	5.19± 0.52	7.0± 1.0	1.5	
ER	EP control w/o electronic driver, w/ wheather pack 4 connector & fine high gain control metering	12V	5.19± 0.52	7.0± 1.0	1.5	
ES	EP control w/o electronic driver, w/ deutsch connector	24V	20.8 ± 2.08	27.7 ± 3.0	0.75	

* Inductance measured at 1 KHZ with coil not installed on core tube.

Electronic Proportional displacement control

(EC, ED)

Interface schematic

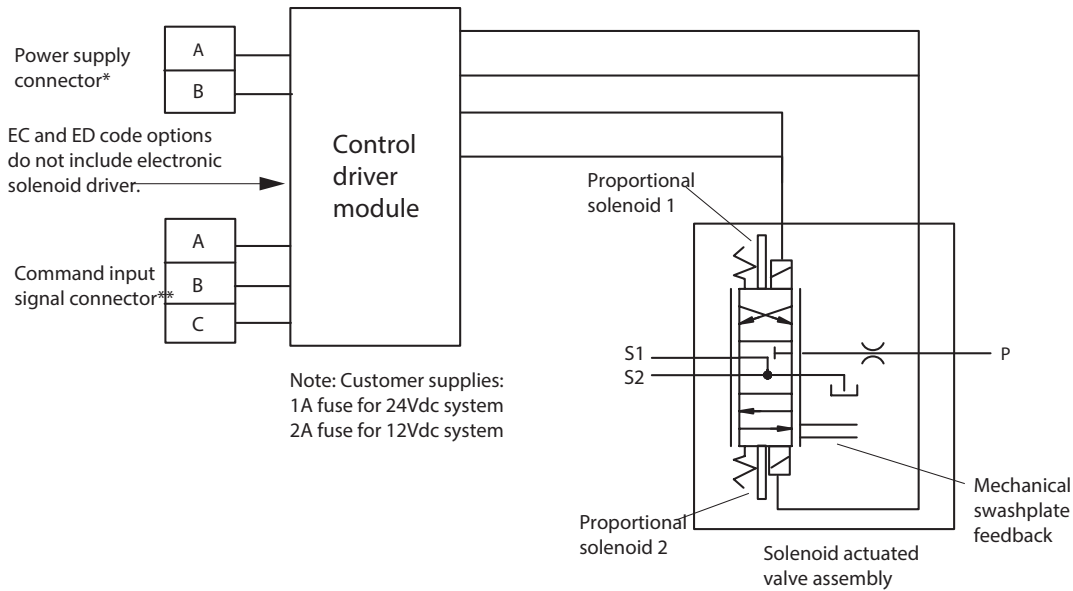

Solenoid actuated valve assembly

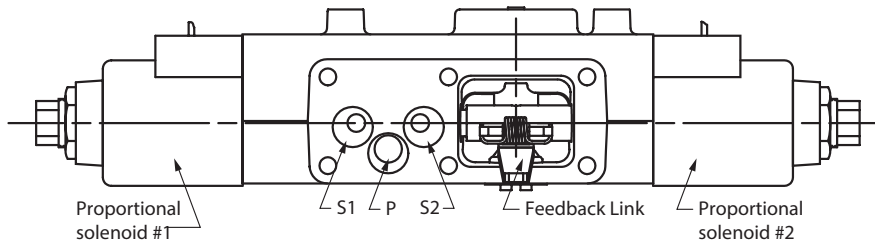

Electronic Proportional valve control guidelines

Parameter	12VDC	24VDC
Signal input *		
Resistance at 25°C - Ohm	5.19 ± 10%	20.80 ± 10%
Nominal inductance	17.5 mH	27.7 mH
Current (I) at Neutral - Amp	< 0.4	< 0.2
Current (I) at full displacement - Amp (max continuous)	1.5A	0.75A
Operating limits		
Temperature ratings	-65°F Min to 140°F Max	
Power consumption	28W Max	

Signal profile

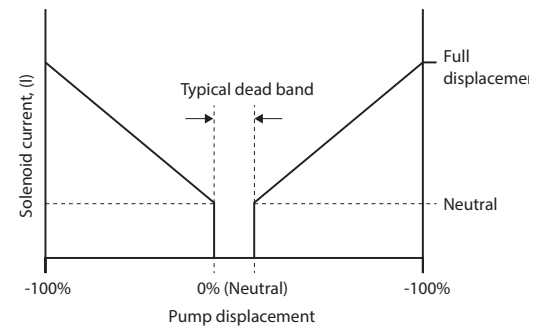

PWM configuration

Closed loop current control of the solenoid current via PWM duty-cycle variation.

Note: Coil currents must be limited to not exceed solenoid coil specifications

Frequency: 70-200Hz

(100Hz recommended when PWM driver does not have built-in dither capabilities)

Dither signal

The design must provide for a separate dither signal to be added to the input command.

Waveform: Square

Frequency: 75 (+ 25,-15) Hz

Amplitude: .250 +.100 -.050A pk-pk

Solenoid operated controls

Code SA

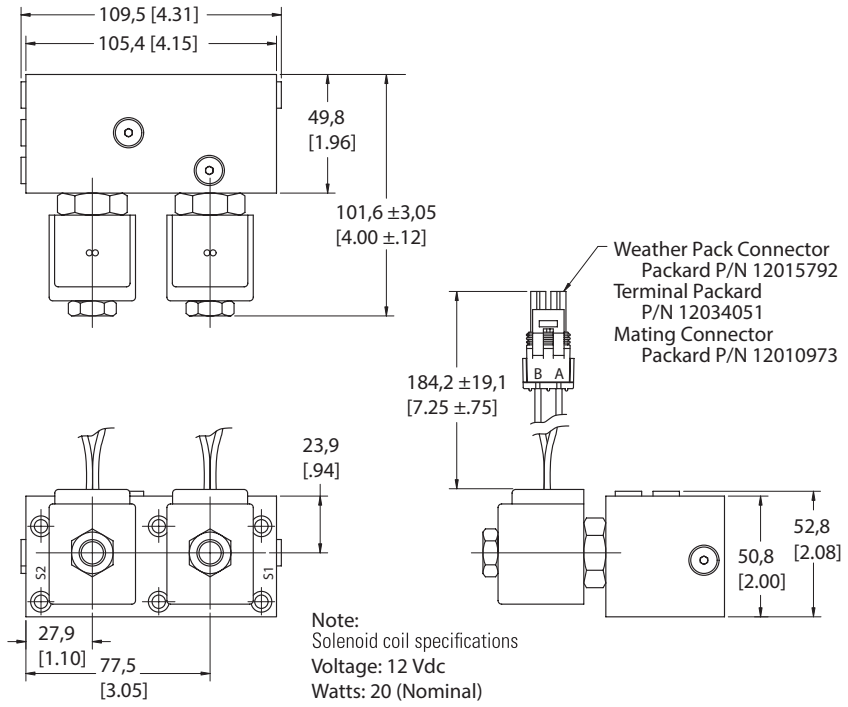
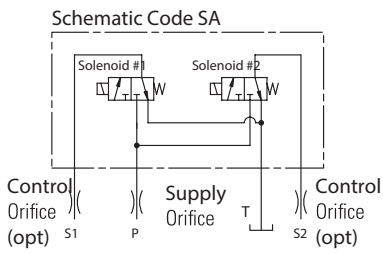

Code SB

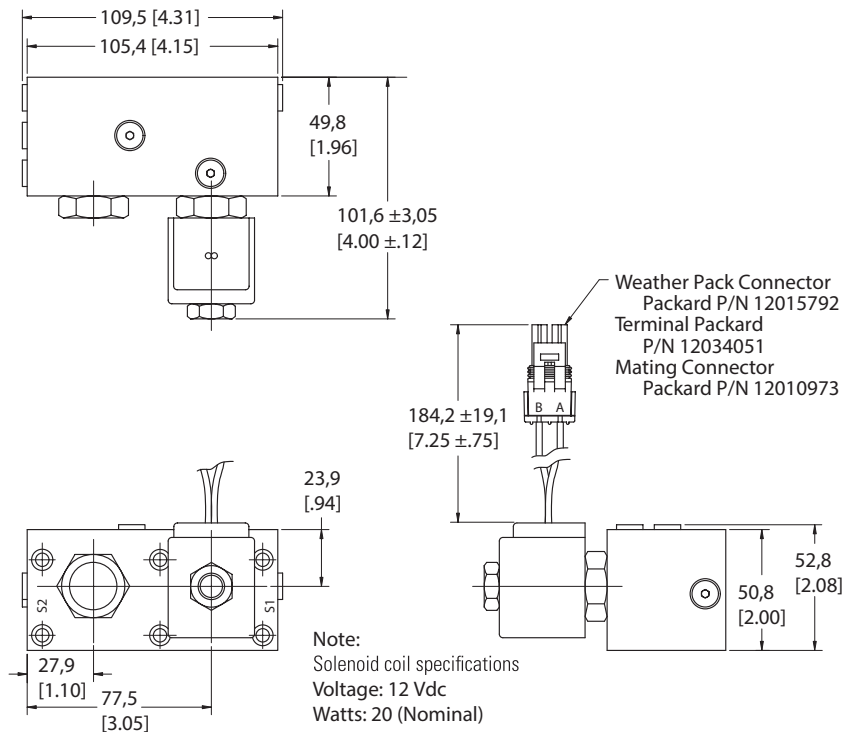
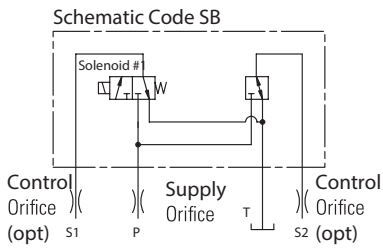

Code SC

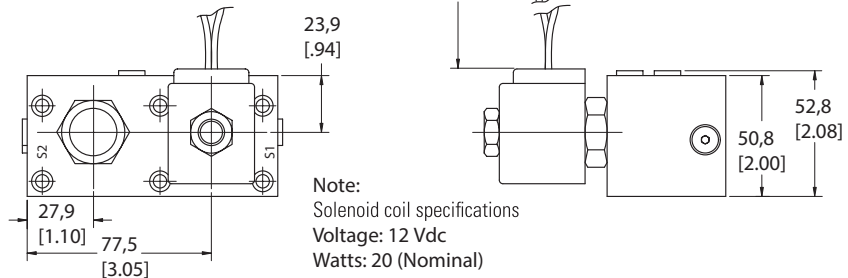
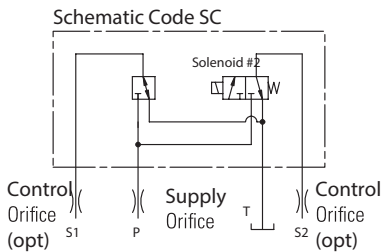

Solenoid control with swash feedback sensor

(SK)

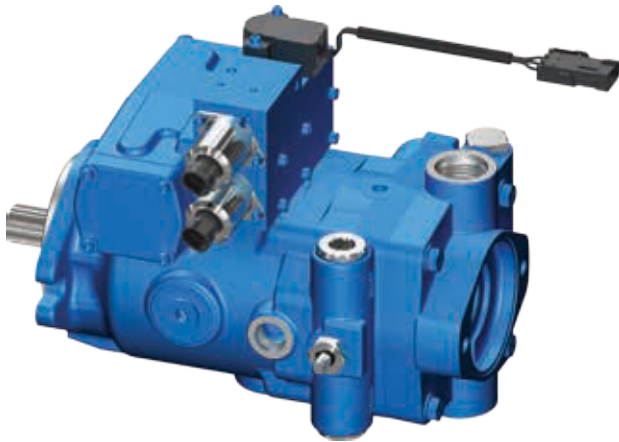

This control has additional swash position sensor which provides angular position of the swash plate very precisely at any point of time during pump operation. Swash position signal is converted in electrical signal and supplied to Electronic Control Unit (ECU) of the hydraulic system. This signal is used to compare the input command to the pump and the output flow. Any deviation in the demand Vs pump output flow is corrected by electric signal from ECU to solenoids which in turn will stroke or de-stroke the pump to match the flow.

Refer Swash sensor section for further details.

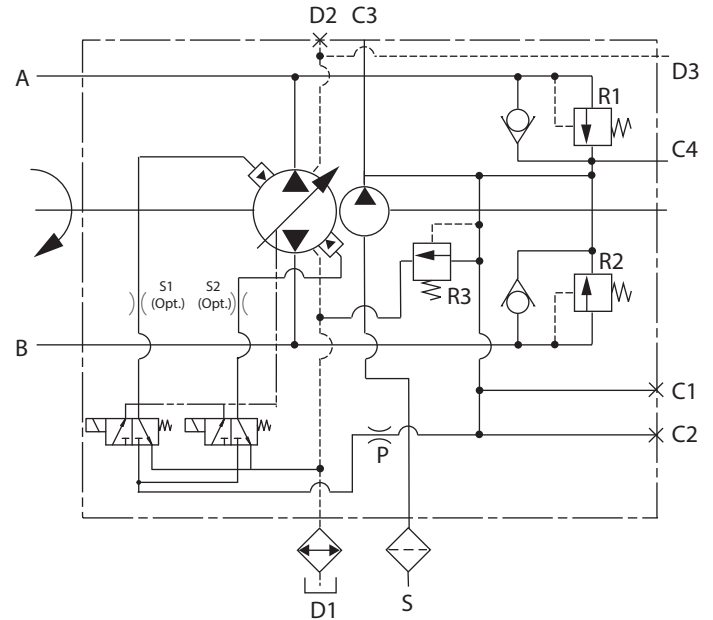

Hydraulic remote control

(HA)

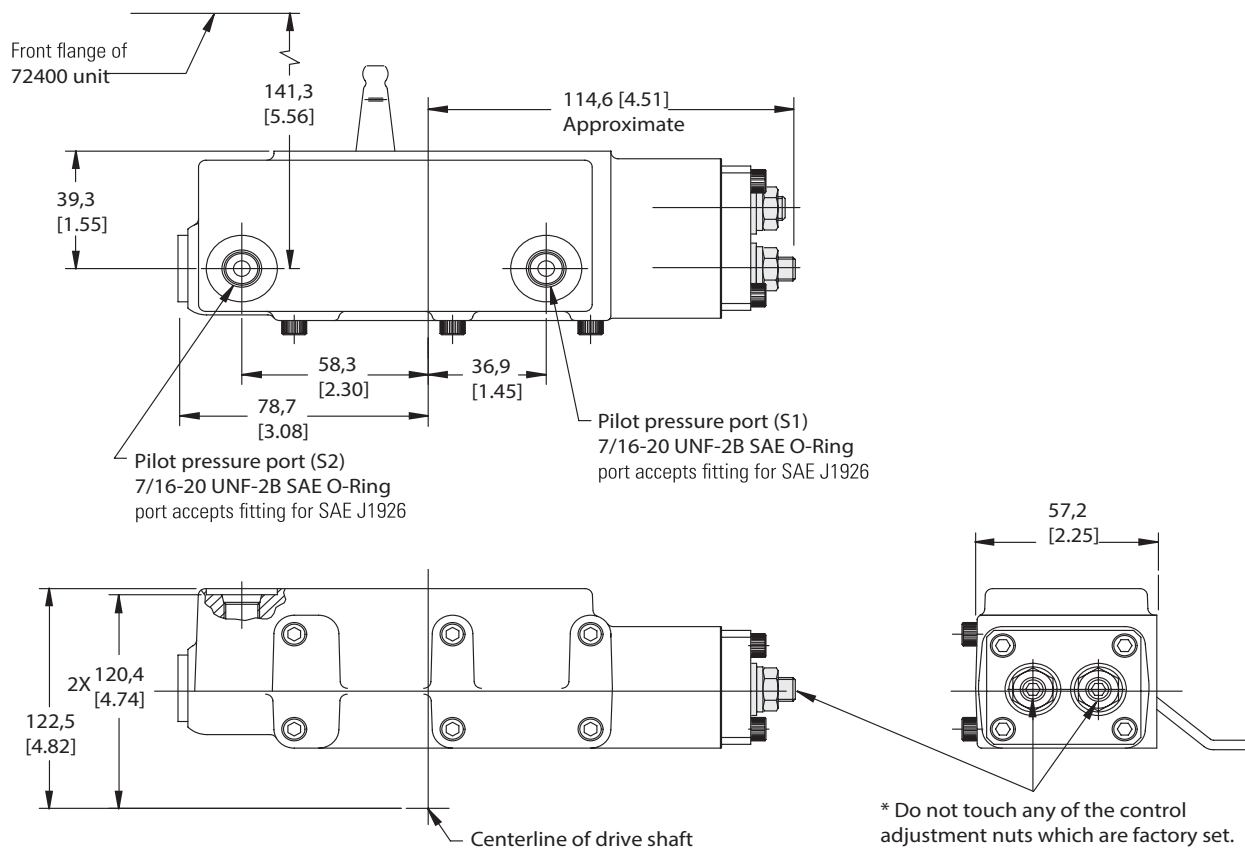
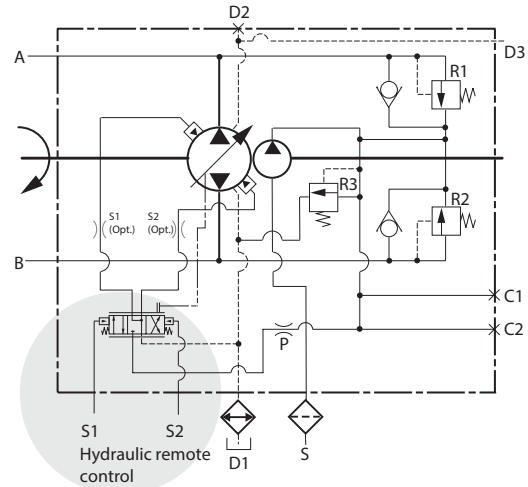
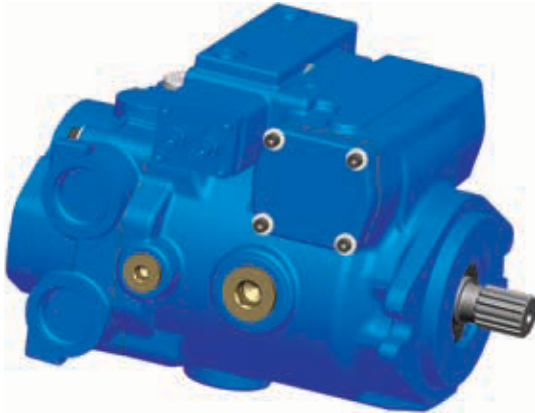

Hydraulic remote control conversion kit

Order part number 72400-919

Includes: Control sub-assembly (1pc), Socket head cap screws (6 pc), Control housing gasket (1pc)

Manual control

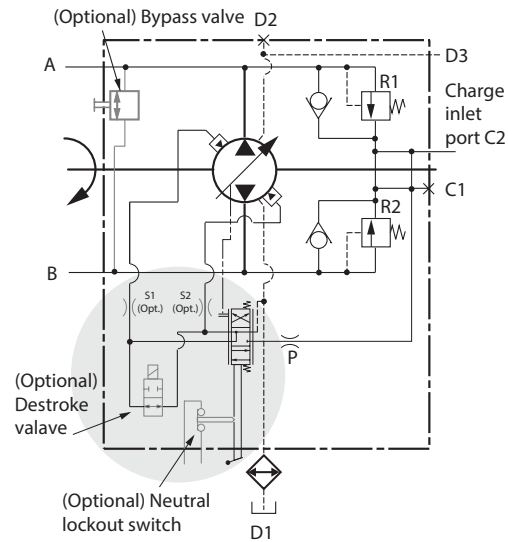
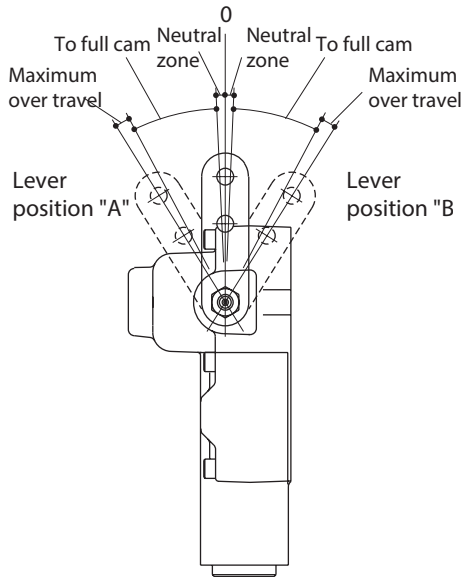

Torque required to move manual control lever – 4.52 N-m [40 lbf-in]

Control Lever Travel	Standard Band	Wide Band	High Gain
Neutral Zone	2.5°	4.0°	3°
Maximum Displacement	25.5°	25.5°	17°
Maximum Over Travel	4.0°	2.5°	10°

Neutral detent feature (MB)

The neutral detent provides a positive, centered feeling to the handle, signaling the operator when the pump is in neutral position.

Neutral lockout feature (MA, MF, MG, MJ, MS)

The neutral lockout switch consists of an electrical switch installed on the controller. This switch closes at the neutral position of the input lever and opens if lever is rotated either direction. The electronic "lockout" prevents the operator from starting any auxiliary functions unless the pump is in neutral position.

Dimensions are in millimeters [inches], unless otherwise specified.

Destroke valve feature

The destroke valve provides an emergency return to neutral and must be energized in order for the pump to stroke. If at any time power is interrupted to the solenoid, the pump will destroke to neutral.

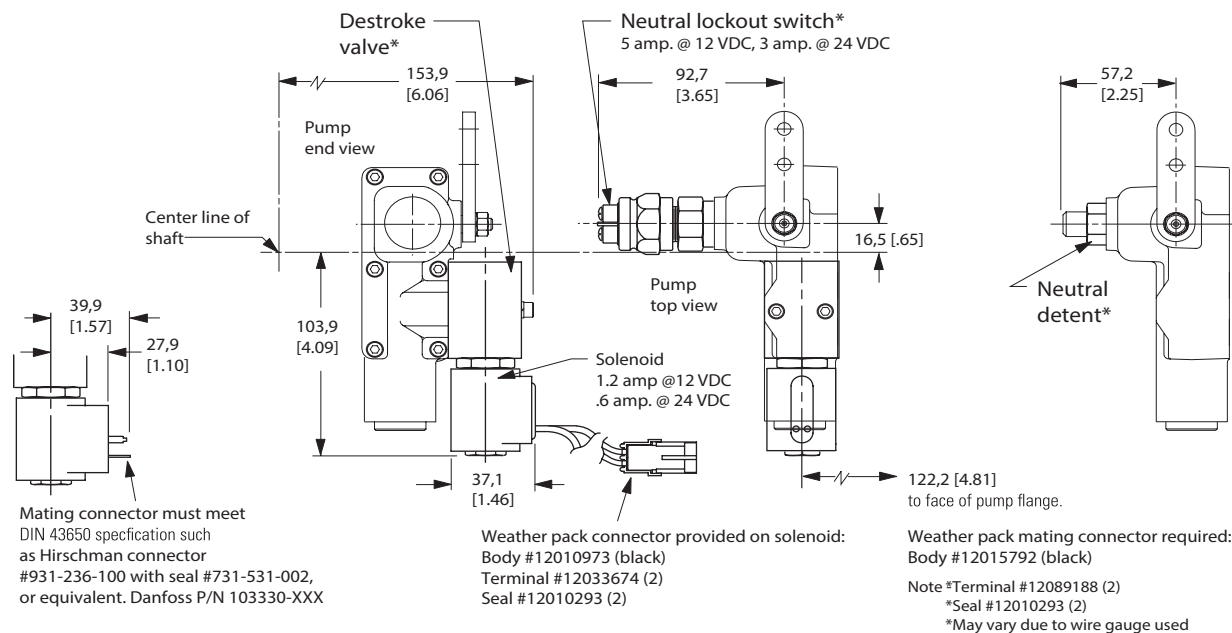

Pump additional features

Brackets

70160

Code "AF" bracket

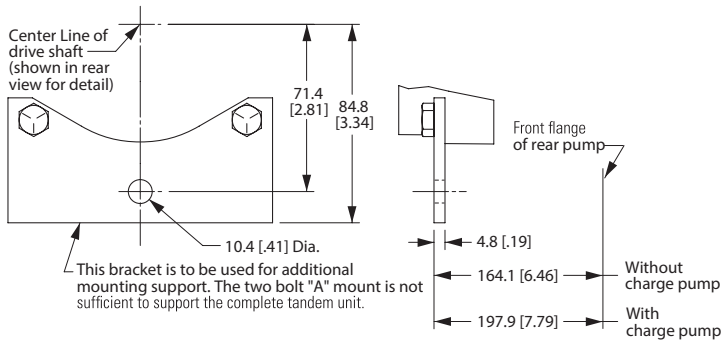

Code "AG" bracket

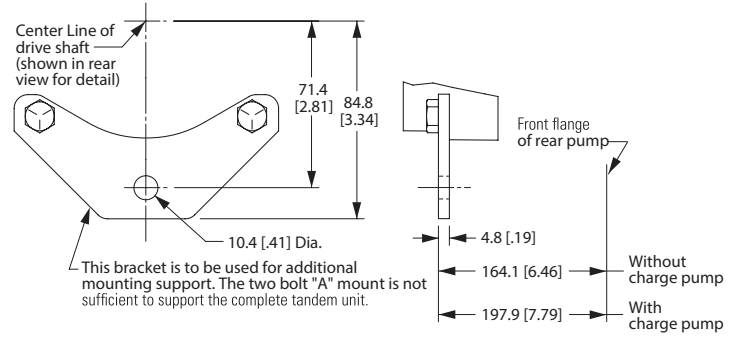

70360

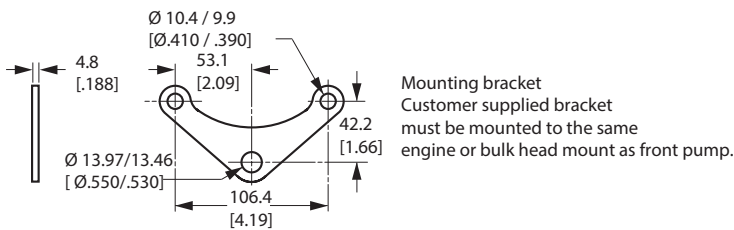

Bleed-off valve

Pump with integral charge

Bleed-off valves are used to bleed oil from the low pressure side of the loop. They are "normally open" valves which close when pressurized to 200-250 psi. These valves close and open abruptly, causing vehicles to lurch when operators move across neutral into

the opposite direction. As designed, a bleed-off valve can withstand flows of .8 to 1.2 gpm. Increasing the flow capacity of the valve will magnify the lurch that operators experience.

Bleed off-valve - normal open position

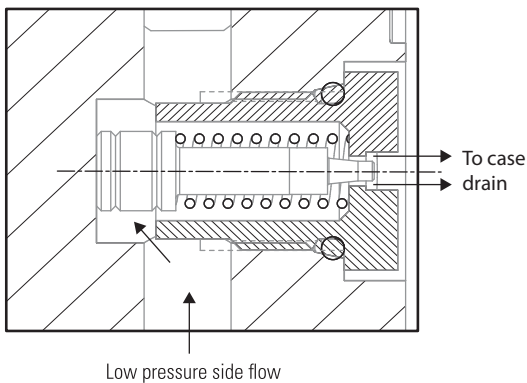

Bleed off-valve - closed position

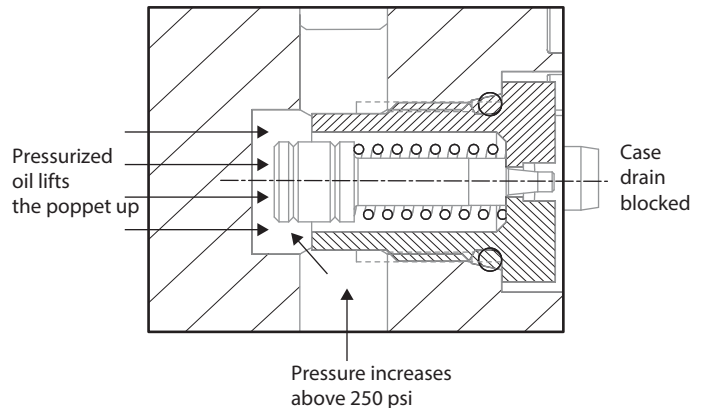

Pump additional features

Bypass/dump valve

(For dimensions, refer to installation drawings.)

Opens the closed loop hydraulic circuit, allowing limited movement of a machine.

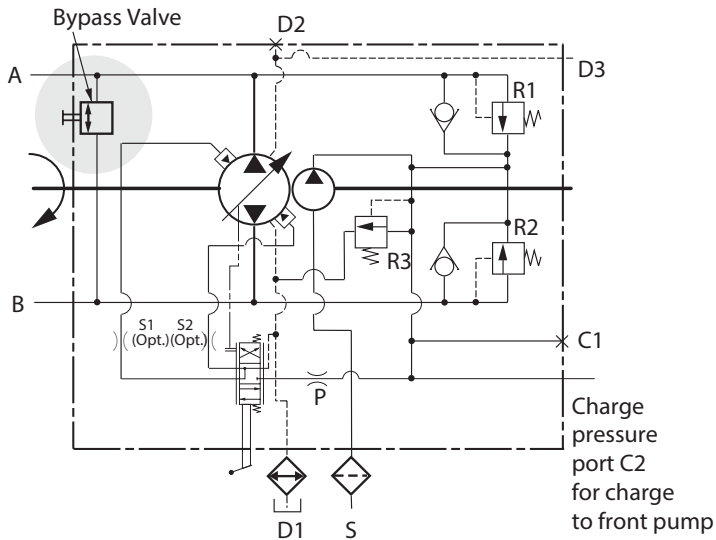
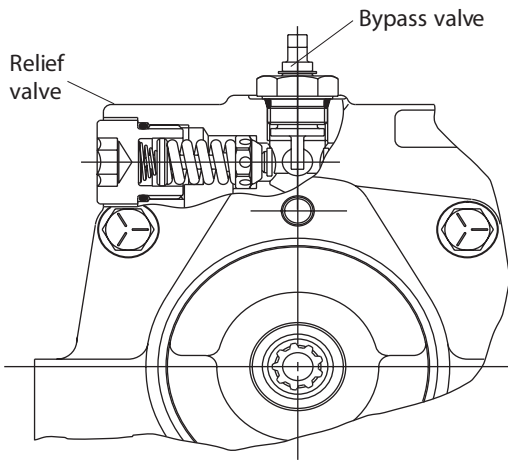

Part # to order Bypass/dump valve separately
 70160 & 70360 = 70300-610
 72400 = 72400-900

Case 1:

Bypass/dump valve in normal condition (Towing is not permitted)

Case 2:

Bypass valve in actuated condition.

ie valve is turned to 90° (either side) which allows to open two HPRV spool & hence both the ports are connected to each other and towing to a short distance is permitted in this condition.

Bypass valve is in normal condition. When Bypass valve is rotated by 90° (flat is parallel to shaft axis) Towing is not permitted. When Bypass valve is rotated by 90° (flat becomes perpendicular to shaft axis) Towing is permitted.



Note: Valve could be rotated by 360°. For towing operation 90° (either side) rotation is required.

Pump additional features

Supply and control orifice on model 72400

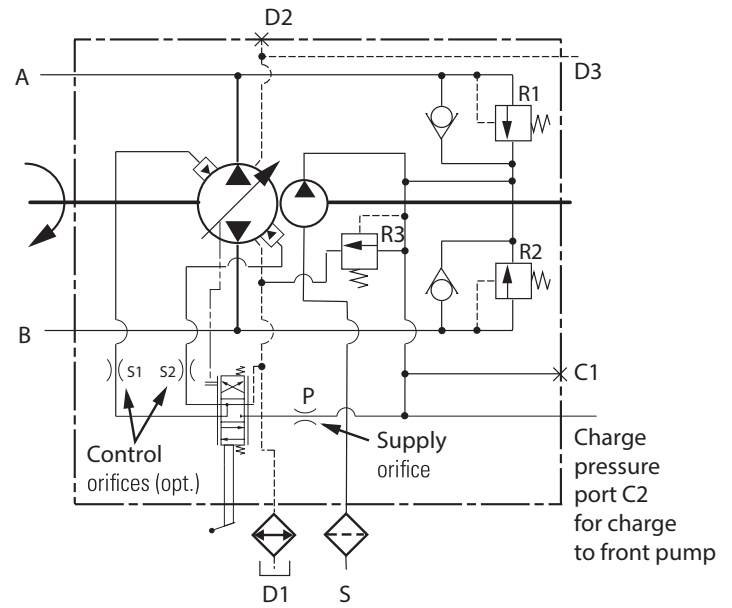
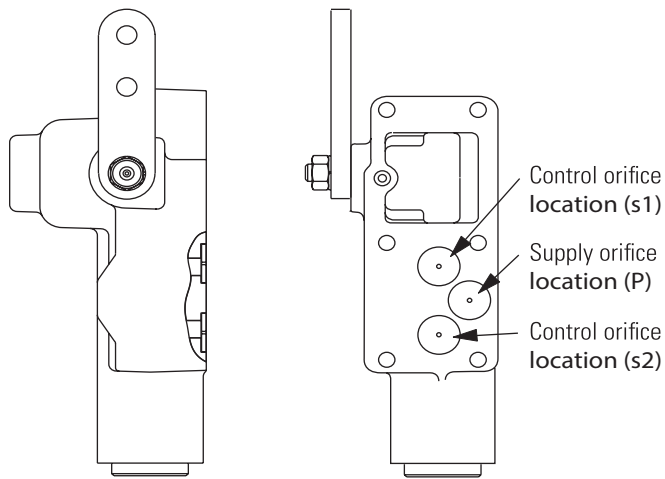

Calculated time from neutral to full stroke (seconds)

Control orifice size, mm [in]

Supply orifice size mm [in]	0.71 [0.028]	0.81 [0.032]	0.91 [0.036]	1.02 [0.040]	1.12 [0.044]	1.32 [0.052]	1.45 [0.057]	None
0.71 [0.028]	1.245	1.148	1.085	1.043	1.015	0.983	0.972	0.946
0.81 [0.032]	1.199	1.089	1.013	0.961	0.925	0.881	0.866	0.828
0.91 [0.036]	1.173	1.053	0.968	0.907	0.863	0.808	0.788	0.736
1.02 [0.040]	1.157	1.031	0.939	0.871	0.821	0.756	0.731	0.662
1.12 [0.044]	1.147	1.017	0.920	0.847	0.792	0.718	0.688	0.602
1.32 [0.052]	1.136	1.001	0.899	0.820	0.758	0.670	0.633	0.510
1.45 [0.057]	1.133	0.996	0.892	0.810	0.745	0.652	0.611	0.465
1.65 [0.065]	1.129	0.991	0.885	0.801	0.734	0.634	0.589	0.408
1.85 [0.073]	1.128	0.988	0.881	0.796	0.727	0.624	0.576	0.364
None	1.125	0.984	0.875	0.787	0.716	0.606	0.553	0.138

Pump additional features

Swash position sensor

- The swash feedback sensor enables the system to accurately signal the swash position and provide input to Electronic Control Unit (ECU).
- This signal can be used by ECU to indicate pump neutral/stroking position to operator & to actuate any auxiliary attachment/ implement on vehicle.
- Pump neutral signal can be used as safety mechanism that avoids accidental start of engine / implement when the pump is in stroke.

For 70360 pump

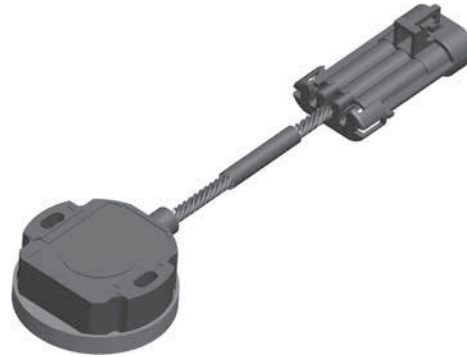

Technical specifications

Input voltage	5 ± 0.5 VDC
Input current	11 mA (Redundant Sensor)
Input current	22 mA (Non -Redundant Sensor)
Output voltage	2.5 ± 0.01 VDC
Temperature range	-40 °C to 120 °C

For 72400 pump

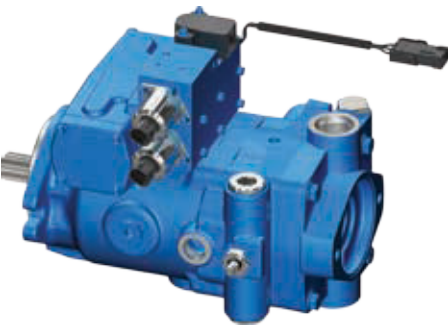

Technical Specifications

Input voltage	5 ± 0.5 VDC
Input current	10 mA
Output voltage	2.5 ± 0.01 VDC
Output current	-1 to 1 mA
Sensitivity	1.0 volt per 10° shaft rotation
Temperature range	-40 °C to 120 °C

Connector	Mating Connector	Harness Length (inch)
Delphi packard weather pack- 3 way connector (Shroud)	Delphi packard weather pack- 3 way connector (Tower)	5.25 ± 0.50
Delphi packard weather pack- 3 way connector (Tower)	Delphi packard weather pack- 3 way connector (Shroud)	5.25 ± 0.50

Pump additional features

Speed sensor

Magnetic speed sensor is used to measure the speed of the drive shaft. This is optional feature. Cylinder barrel has cutouts made on its periphery. Magnetic speed sensor senses the speed of these cutouts and converts it into required RPM signal. This does not sense the direction of rotation of the pump.

Mating packard connector

- Connector body – 1216 2192
- Connector seal – 1204 0750
- Cable seal – 1204 0751
- Socket – 1212 4075

Optional mating connectors

- Connector assembly (body, cable seal, seal) – 1216 2193
- Socket (16 – 18 AWG) – 1212 4075
- Socket (20 – 22 AWG) – 1212 4076

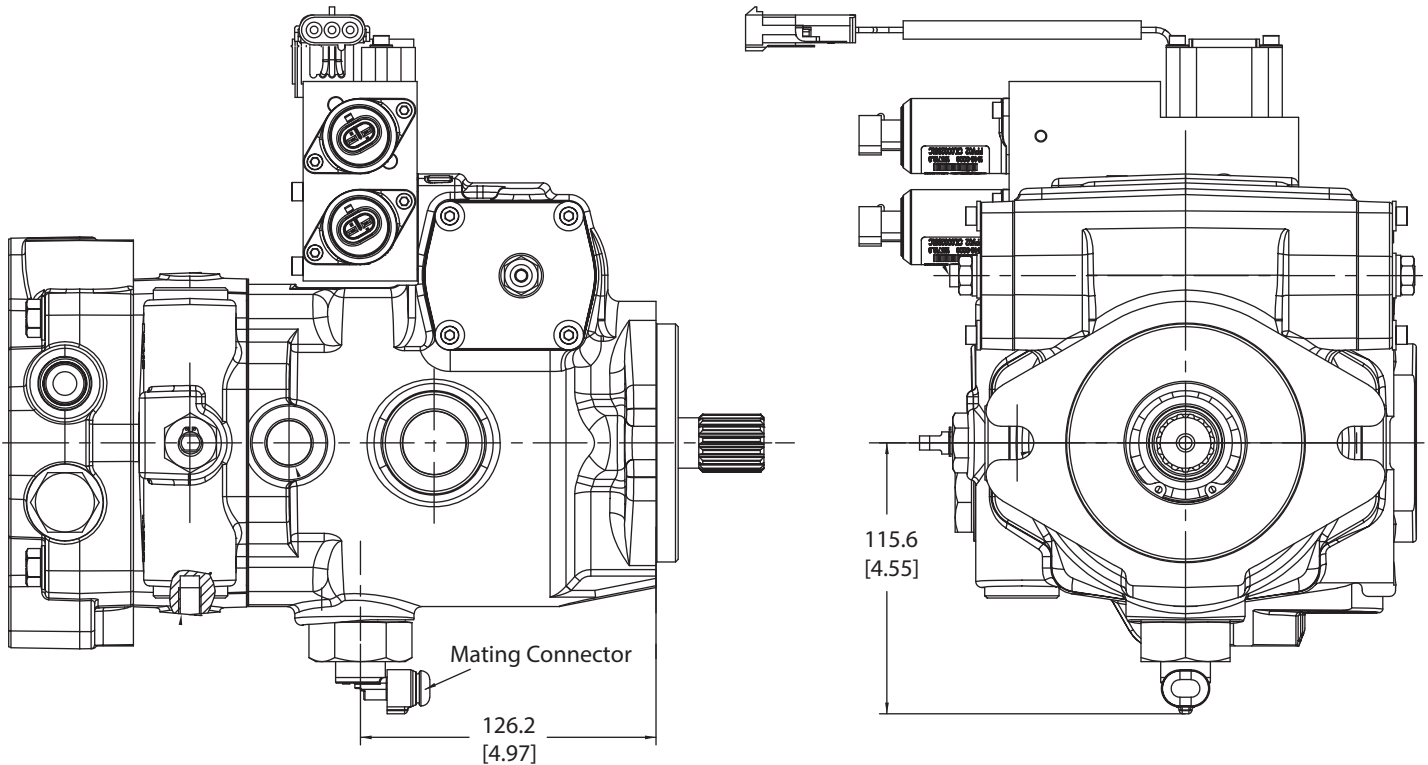

Condition	Condition	Value
Operating temperature limit		-40 to 150°C [-40 to 302°F]
Sensor resistance	25°C (77°F)	1.5 K To 3.5 K Ohms
Sensor inductance	25°C (77°F)	0.6 to 3.7 H
Output voltage	25°C (77°F) 9.3 Hz @ 2.29mm [.090 inch] gap 300 Hz @ 0.25mm [.010 inch] gap	400 mVpp min 80 Vpp max.
Air gaps		0.26 to 2.28 [.010 to .090] mm [inch]
Vibration voltage	15G random vibration	0.4V P-P Max

Pump additional features

Adjustable displacement limiter on model 72400

- Externally adjustable displacement
- Settings are zero to maximum pump displacement
- Independent adjustment for both main ports
- Field adjustable
- Available in kit form (see page 62)

All factory units shipped with adjustable stops are set at maximum pump displacement.

See re-adjustment instructions below.

To calculate displacement required

The displacement required divided by displacement of one turn of set screw equals the number of turns of set screw to obtain displacement.

Example for 3.00 in³/r re-adjustment:

$$2.0 \text{ in}^3/\text{r} \div .2854 \text{ in}^3/\text{r} = 7 \text{ turns of set screw}$$

To re-adjust displacement

- Loosen nut on adjustable set screw #81 servo stop. Screw stop in until it touches the servo piston. Back the screw out (number of turns required) to obtain the flow required. Refer to chart for displacements. Lock adjustment with nut. Torque nut 8 to 11 N-m [68 to 96 lbf·in]
- Loosen nut on adjustable set screw #74 servo stop. Screw stop in until it touches the servo piston. Back the screw out (number of turns required) to obtain the flow required. Refer to chart for displacements. Lock adjustment in place with nut. Torque nut 17 to 18 N-m [150 to 160 lbf·in]

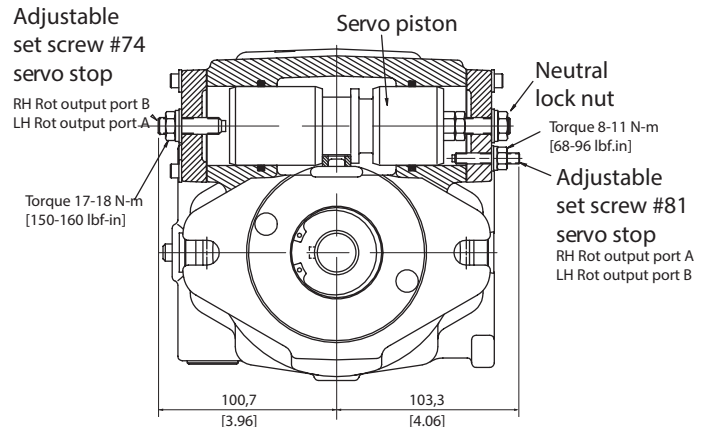

Pump displacement per turn

2.48 in³/r Pump Displacement @ Full Cam

Turns of set screw	Item # 74 stop	Item # 81 stop
0	2.48 in ³ /r	2.48 in ³ /r
1	2.22 in ³ /r	2.26 in ³ /r
2	1.98 in ³ /r	2.05 in ³ /r
3	1.73 in ³ /r	1.84 in ³ /r
4	1.49 in ³ /r	1.63 in ³ /r
5	1.26 in ³ /r	1.43 in ³ /r
6	1.03 in ³ /r	1.23 in ³ /r
7	0.80 in ³ /r	1.03 in ³ /r
8	0.57 in ³ /r	0.83 in ³ /r
9	0.34 in ³ /r	0.63 in ³ /r
10	0.12 in ³ /r	0.44 in ³ /r
10.5	0.01 in ³ /r	0.34 in ³ /r
11	N/A	0.25 in ³ /r
12.0	N/A	0.05 in ³ /r
12.3	N/A	0.00 in ³ /r

3.0 in³/r Pump Displacement @ Full Cam

Turns of set screw	Item # 74 stop	Item # 81 stop
0	3.00 in ³ /r	3.00 in ³ /r
1	2.71 in ³ /r	2.75 in ³ /r
2	2.40 in ³ /r	2.49 in ³ /r
3	2.11 in ³ /r	2.23 in ³ /r
4	1.82 in ³ /r	1.98 in ³ /r
5	1.53 in ³ /r	1.74 in ³ /r
6	1.25 in ³ /r	1.49 in ³ /r
7	0.97 in ³ /r	1.25 in ³ /r
8	0.69 in ³ /r	1.01 in ³ /r
9	0.42 in ³ /r	0.77 in ³ /r
10	0.14 in ³ /r	0.54 in ³ /r
10.5	0.01 in ³ /r	0.42 in ³ /r
11	N/A	0.30 in ³ /r
12.0	N/A	0.07 in ³ /r
12.3	N/A	0.00 in ³ /r

Metric conversion: Displacement $\times 16.387 = \text{cm}^3/\text{r}$

Pump additional features

Adjustable displacement limiter kit

Field installed kits

- One side Kit #72400-938
- Two sides Kit #72400-940

Disassembly

- Remove the four cap screws (Item #7) and washers (Item #61) retaining the existing cover plate (Item #11) opposite neutral set screw
- After removing existing cover plate (Item #11) and cover gasket, measure the distance from the servo piston to the surface of housing for reference for neutral setting
- Remove neutral setting nut (Item #2)
- Remove the four cap screws retaining the existing cover plate (Item #17)
- The cover plate (Item #17) is screwed onto the servo piston bolt. When removing the cover plate, count the amount of turns it takes to remove cover for reassembly. Also remove existing gasket (Item #12)

Installing servo stops

- Place new gasket (Item #12) onto the housing on the neutral setting screw side of the servo piston. Hold in position with a small amount of petroleum jelly
- Screw new cover plate (Item #17) onto servo piston bolt the same number of turns as it took to remove it. Install the four cap screws (Item #7) and washers (Item #61) to retain cover plate. Torque 4.5 to 5.4 N-m [40 to 48 lbf-in]
- Install seal washer (Item #6), washer (Item #60) and jam nut (Item #2). Torque nut 17 to 18 N-m [150 to 160 lbf-in]. At this time, check the distance from the servo piston to housing surface on opposite side. It should be the same as previously measured at disassembly. If not the same, loosen jam nut and with a hex key wrench, adjust and retorque nut
- Install new cover plate (Item #11) and retain with four cap screws (Item #7) and washers (Item #61). Torque 4.5 to 5.4 N-m [40 to 48 lbf-in]
- Insert adjustable servo stop set screw (Item #81) in until it touches the servo piston. Back the screw out to obtain the flow required. Refer to chart for displacements. Lock adjustment into place with seal washer (Item #83), washer (Item #82), and jam nut (Item #80). Torque nut 8 to 11 N-m [68 to 96 lbf-in]
- Insert adjustable servo stop set screw (Item #74) in until it touches the servo piston. Back the screw out to obtain the flow required. Refer to chart for displacements. Lock adjustment into place with seal washer (Item #6), washer (Item #60), and jam nut (Item #2). Torque nut 17 to 18 N-m [150 to 160 lbf-in]

Adjustable Servo Stop Kit Parts			Kit #72400-938	Kit #72400-940
Item #	Part number	Description	Quantity	Quantity
2	16024-6	Jam Nut	1	2
6	16254-6	Seal Washer	1	2
11	72400-651	Cover Plate	1	1
12	72400-621	Cover Gasket	1	2
17	72400-771	Cover Plate		1
60	16254-26	Washer	1	2
74	16139-624	Set Screw	1	1
80	16022-4	Jam Nut		1
81	16139-424	Set Screw		1
82	16254-24	Washer		1
83	16254-4	Seal Washer		1

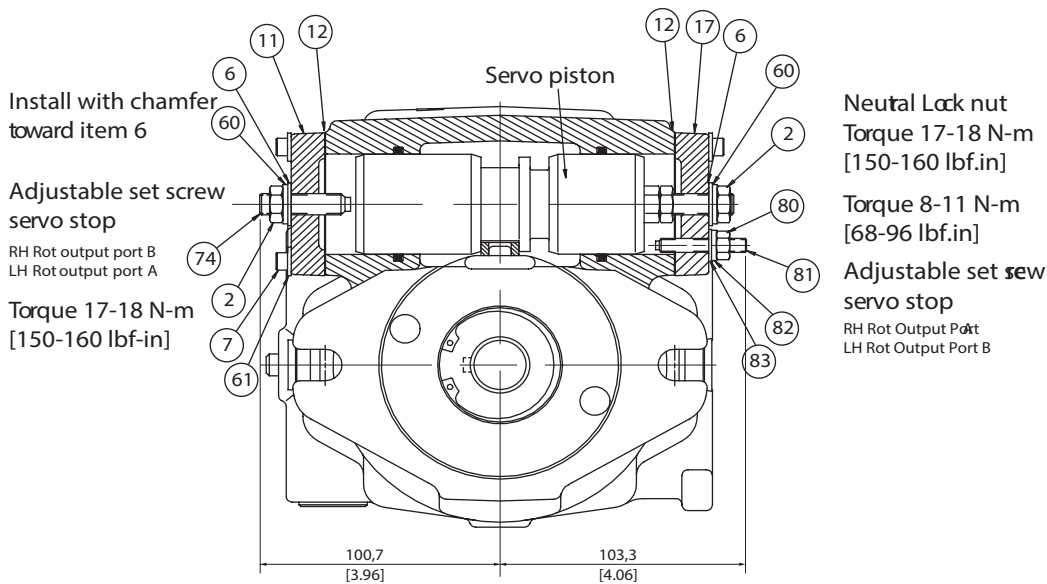

Pump mounting and shafts

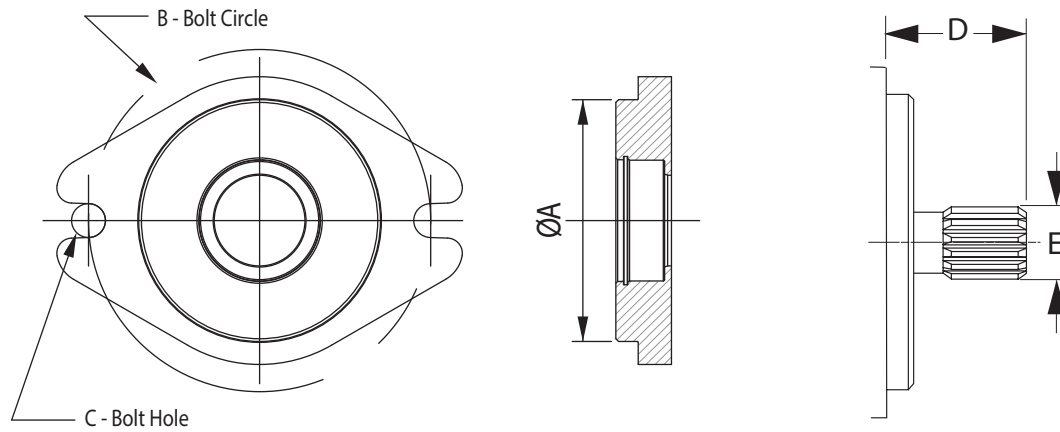

Mounting flange as per SAE J744	For Size (cm ³ /r)	Pilot Dia. A (mm)	Bolt Circle B (mm)	Bolt Hole C (mm)	Screw	Washer (mm)	Torque 8.8 (N-m)	Torque 10.9* (N-m)
SAE A, 2 Bolt	20.24	82.6	106.4	11.1	M10	12.5x 25x 4	46	65
SAE B, B-B, 2 Bolt	41.49	101.6	146	14.3	M12	12.5x 25x 4	80	110

* Options for standard design, necessary for tandem units

Input shaft options and torque carrying capacity

	Model Code Option			Shaft extn. - D	OD - E	Displacement cm ³ /rev (in ³ /r)				Torque
Shaft per ANSI B92.1	70160	70360	72400	mm [in]	mm [in]	20.3 (1.24)	23.6 (1.44)	40.6 (2.48)	49.2 (3.0)	N-m [lbf-in]
Splined-13T, 16/32 pitch	A	C	C	41 [1.62]	21.8 [0.858]	✓	✓	✓	✓	209 [1852]
Splined-15T, 16/32 pitch	D	A	A	46 [1.81]	24.98 [.983]	✓	✓	✓	✓	338 [2987]
Straight keyed shaft	F	E	NA	46 [1.81]	22.2 [.875]	✓	✓	✓	✓	209 [1852]
Straight keyed shaft	NA	G	G	46 [1.81]	25.4 [1.0]			✓	✓	338 [2987]
Taper shaft	NA	D	D	35.1 [1.35]	25.4 [1.0]			✓	✓	338 [2987]

NA = Not Available

Auxiliary rear mounts and output shafts

Dimensions are in mm [in] unless noted otherwise.

Aux Pump Mount SAE -J744	Shaft per ANSI B92.1	Spline ID mm [in]	Aux Pump Shaft Extension	Need Coupler?			Max output Torque – N-m [lbf-in]	
				70160	70360	72400	(w/charge pump)	(w/o charge pump)
A	9T, 16/32 DP	15.88 [.625]	31.7 [1.25]	No	No	No	54 [480]	76 [672]
A	11T, 16/32 DP	19.33 [.761]	31.7 [1.25]	Yes	Yes	No		119 [1050]
B	13T, 16/32 DP	21.81 [.858]	21.81 [.858]	NA	Yes	No		209 [1852]
B	41T, 48/96 DP (for tandem pump only)	22.22 [.875]	22.23 [.875]	NA	Yes	Yes		316 [2800]

NA = Not Available
For Non-standard shaft options contact Danfoss representative

Auxiliary mount with charge pump

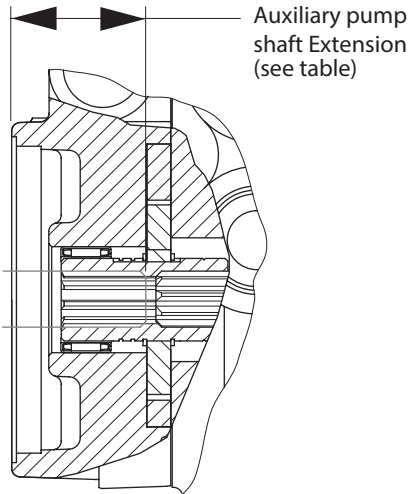

Auxiliary mount without charge pump

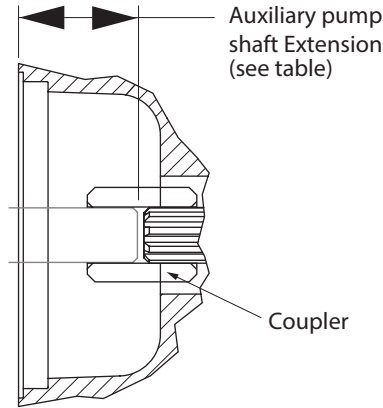

Cover plate

Fits "A" SAE auxiliary mounting flange. Cover plate kit #70142-915: Includes plate, cap screws (2), and O-Ring

All left (CCW) or right (CW) directions given are viewed from the input shaft end of the pump.

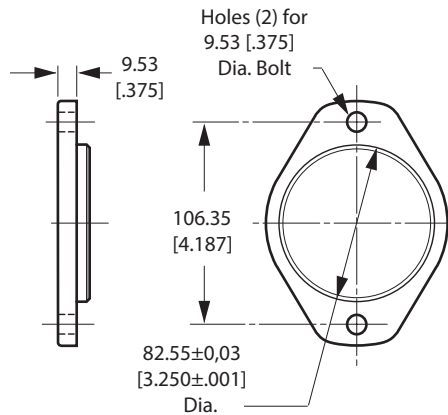

Dimensions are in mm [in] unless noted otherwise.

Tandem servo piston pump SAE "B" mounting kit #72400-902: includes 41T coupling, O-Ring, cap screws (2), and washer.

Installation dimensions

Single pumps

70160 Single

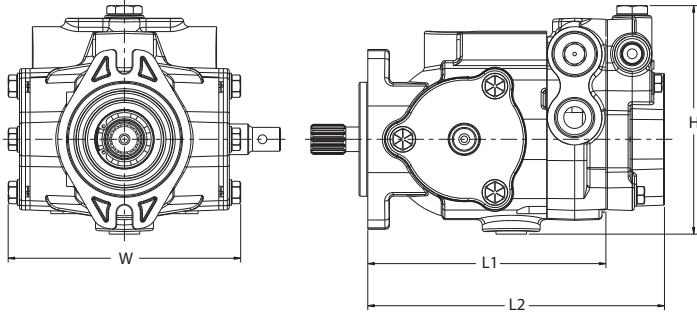

70360 Single

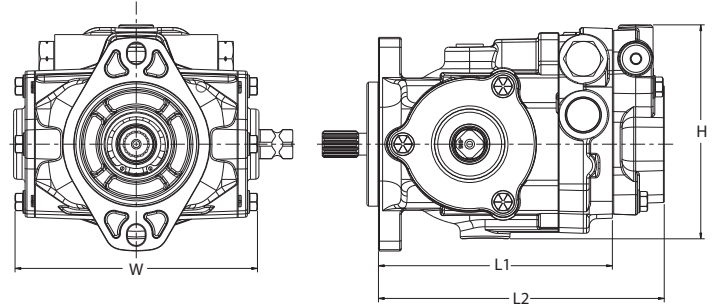

72400 Single

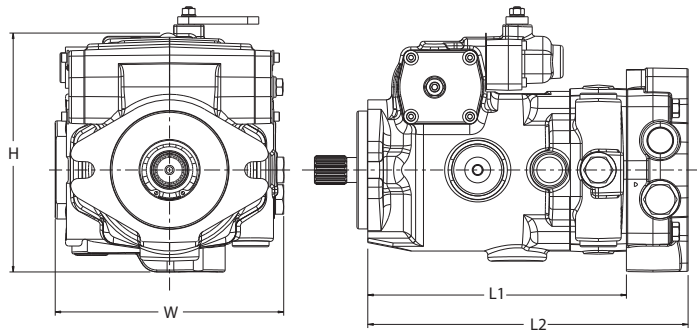

Installation dimensions – mm (inch)

Pump series	Single (Same side ports)			Single (Opposite side ports)		
	70160	70360	72400	70160	70360	
Length	W/o Integral charge pump – L1	206.6 [8.14]	217.0 [8.54]	239.5 [9.43]	182.4 [7.18]	193.3 [7.61]
	W/ Integral charge pump – L2	NA	NA	274.7 [9.66]	214.9 [8.46]	233.7 [9.2]
Width - W	165.8 [6.53]	200.6 [7.90]	103.4 [4.07]	165.8 [6.53]	200.6 [7.90]	
Height - H	165.9 [6.53]	183.9 [7.24]	223.3 [8.79]	159.4 [6.27]	175.5 [6.91]	

* Please contact Danfoss representative for installation dimensions of specific configurations

* Opposite side ports not available on 72400 pumps

* Refer separate installation drawings for control shafts & control installation

Installation dimensions

Multiple pumps

70160 Tandem

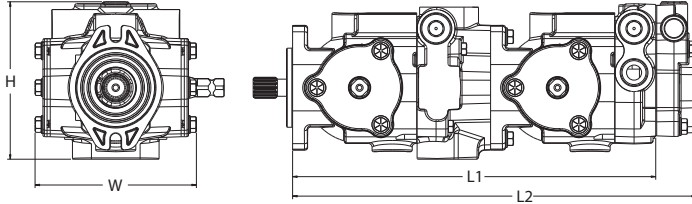

70360 Tandem

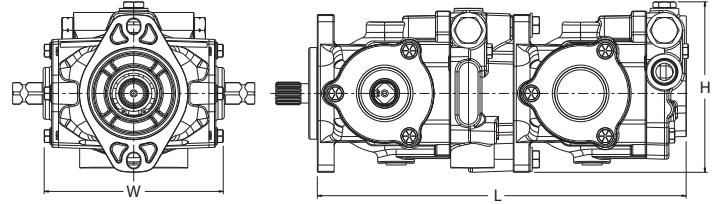

Installation dimensions – mm (inch)

Pump Series	Tandem (Same side ports)			Tandem (Opposite side ports)	
	70160	70360	72400	70160	70360
Length	W/o Integral charge pump – L1	364.4 [14.35]	410.3 [16.15]	364.8 [14.36]	410.3 [16.15]
	W/ Integral charge pump – L2	421.4 [16.59]	NA	413.3 [16.27]	461.7 [18.18]
Width - W	165.8 [6.53]	200.6 [7.90]	204.0 [8.03]	165.8 [6.53]	200.6 [7.90]
Height - H	159.8 [6.3]	183.9 [7.24]	223.3 [8.79]	159.4 [6.27]	188.8 [7.43]

* Please contact Danfoss representative for installation dimensions of specific configurations

Back to Back pumps

70360 Back to Back

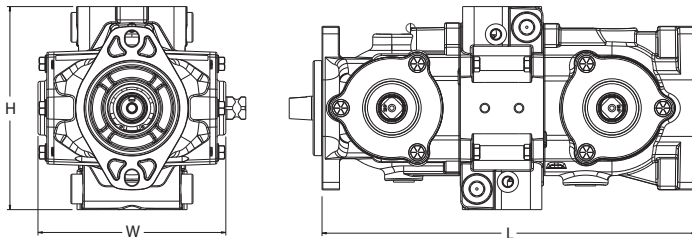

72400 Back to Back

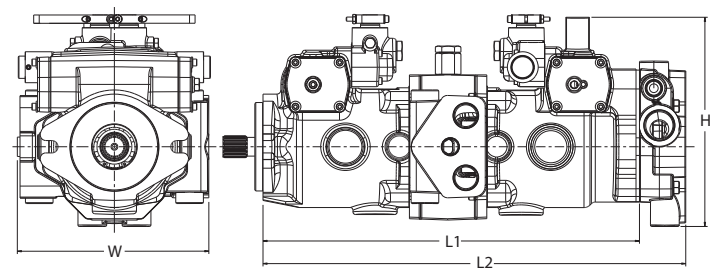

Installation dimensions – mm (inch)

Pump series	Back to Back	
	70360	72400
Length	W/o Integral charge pump – L1	399.9 [15.74]
	W/ Integral charge pump – L2	485.8 [19.13]
Width - W	200.6 [7.90]	220.1 [8.67]
Height - H	223.2 [8.79]	234.1 [9.22]

* Please contact Danfoss representative for installation dimensions of specific configurations

Features and port sizes

PortType	7/16-20 UNF-2B	9/16-18 UNF-2B	3/4-16 UNF-2B	7/8 -14 UNF-2B	1 1/16-12 UN-2B	1 5/16- 12 UN-2B	M18 X 1.5 Metric O-Ring Port	M27 X 1.5 Metric O-Ring Port	M33 X 2 Metric O-Ring Port	-12 Size STCType II+ Direct Port
Pressure Ports				•	• Δ □	□			□	□
Drain Ports			• Δ □		Δ □					
Charge inlet			• Δ □			Δ □		□		
Charge outlet/ Auxiliary			• Δ □	□		□	□			
Diagnostic Ports	□	□								
	• 70160 Δ 70360 □ 72400									

Model 70160

Pump without integral charge

S Charge pressure Inlet port Lefthand Rotation (CCW)
C5 Auxiliary port - for righthand rotation (CW)
C2 Auxiliary port top-rear 3/4-16 UNF-2B SAE O-Ring port
C1 Auxiliary port top -front
C4 Auxiliary port side Lefthand rotation (CCW)
D1(Top) Drain port
D4 Case drain into front Mounting flange (Optional)
S Charge pressure Inlet port Righthand Rotation (CW)
A Main port
B Main port
D2(Bottom) Drain port
C2 Auxiliary port - rear
C1 Auxiliary port top -front
D1 Drain Port - top
D3 Thru Drain - rear
B Main port
A Main port
D2 Drain port - bottom

Port ID	Type of Port	Size and Description
A	Main port	1- 1/16 - 12 UN-2B SAE O-Ring, 7/8 -14 UNF-2B SAE O-Ring
B	Main port	1- 1/16 - 12 UN-2B SAE O-Ring, 7/8 -14 UNF-2B SAE O-Ring
C1	Auxiliary port top front or bypass valve	3/4 - 16 UNF-2B SAE O-Ring
C2	Auxiliary port top - rear	3/4 - 16 UNF-2B SAE O-Ring
C4	Auxiliary port side - left side	3/4 - 16 UNF-2B SAE O-Ring
C5	Auxiliary port side - right side	3/4 - 16 UNF-2B SAE O-Ring
D1	Drain port - top	3/4 - 16 UNF-2B SAE O-Ring
D2	Drain port - bottom	3/4 - 16 UNF-2B SAE O-Ring
D3	Thru drain - rear	9,27 [.365] Dia.
D4	Thru drain - front	9,27 [.365] Dia.
S	Charge suction port	3/4 - 16 UNF-2B SAE O-Ring

All left (CCW) or right (CW) directions given are viewed from the input shaft end of the pump

Features and port sizes

Model 70360

Opposite side porting (selected in position 9)

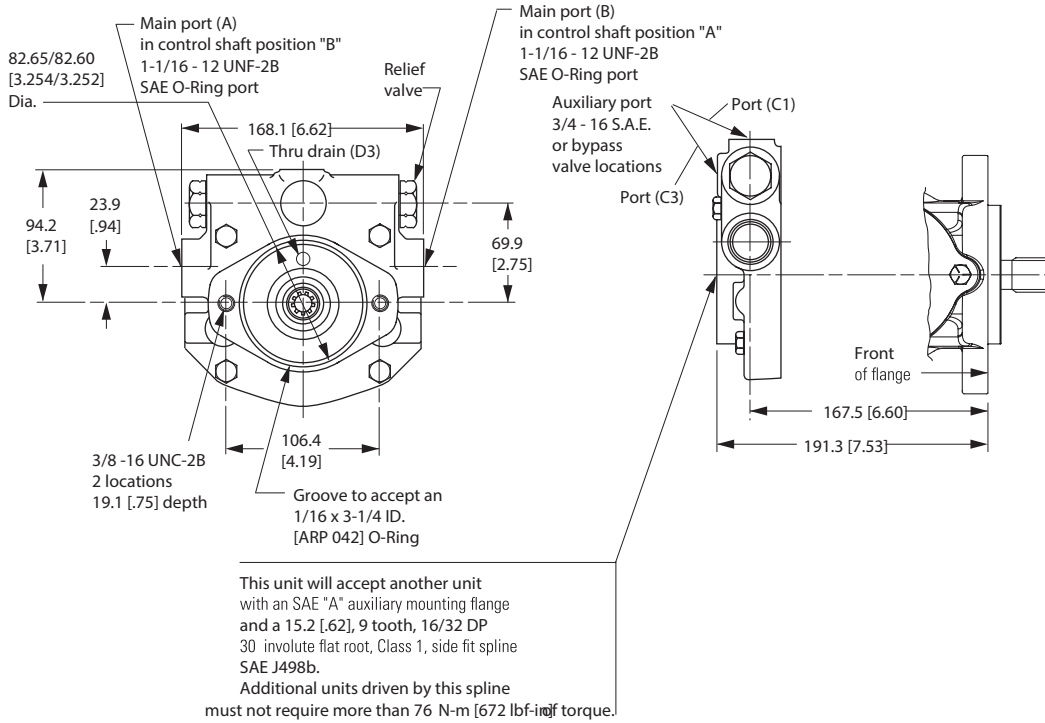

Same side porting (selected in position 9)

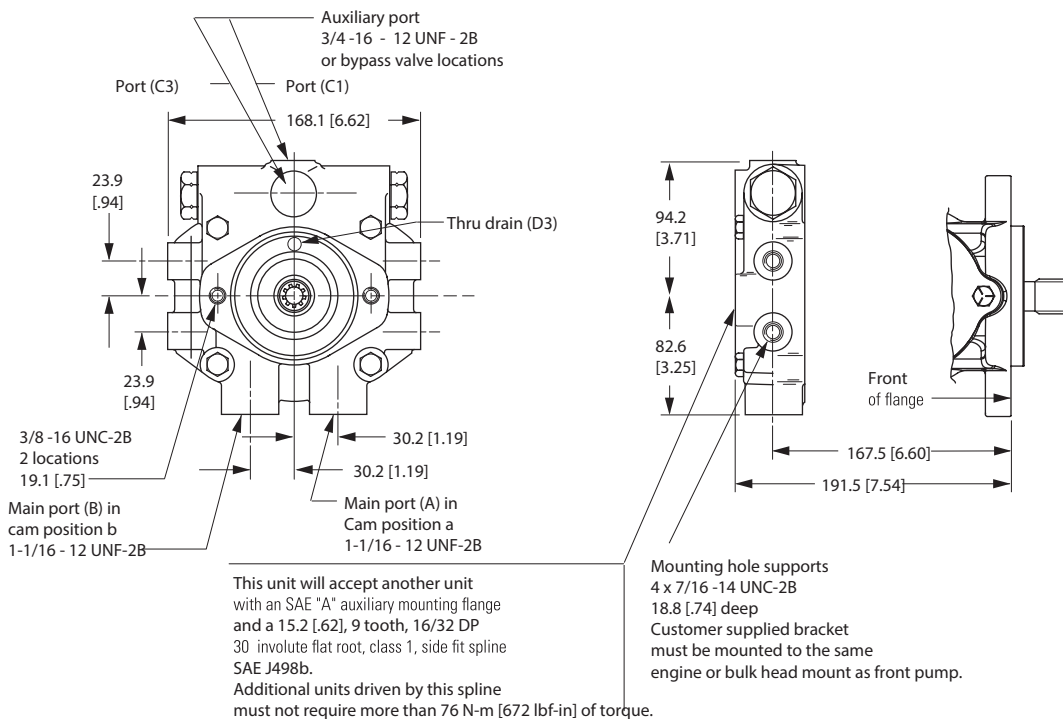

All left (CCW) or right (CW) directions given are viewed from the input shaft end of the pump.

Features and port sizes

Model 70360

Opposite side porting (selected in position 9)

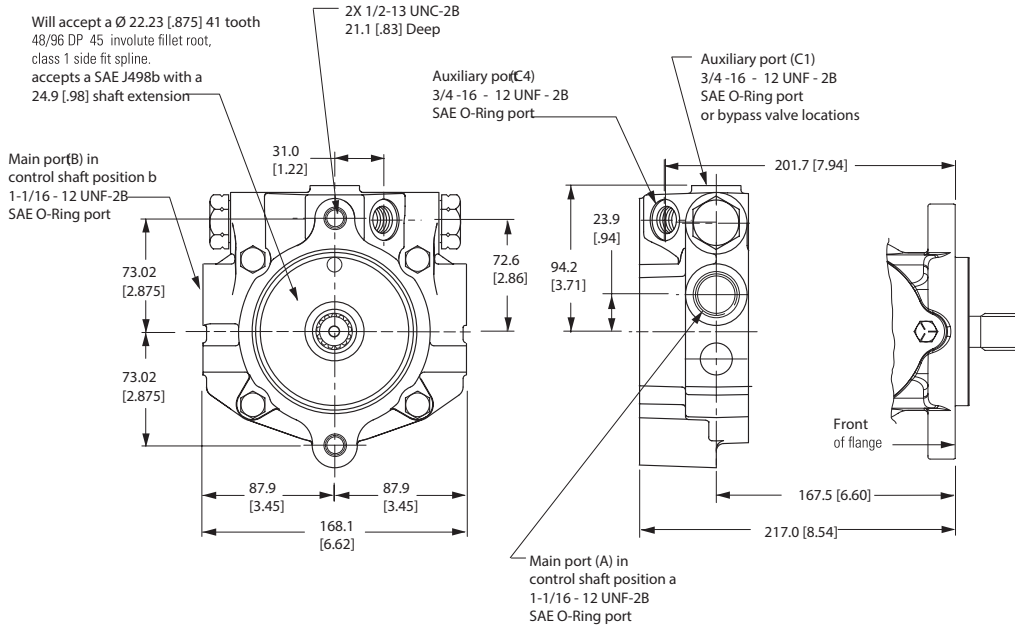

Port ID	Type of Port	Size and Description
A	Main port	1- 1/16 - 12 UN-2B SAE O-Ring
B	Main port	1- 1/16 - 12 UN-2B SAE O-Ring
C1	Auxiliary port top - front or bypass valve	3/4 - 16 UNF-2B SAE O-Ring
C2	Auxiliary port top - rear	3/4 - 16 UNF-2B SAE O-Ring
C3	Auxiliary port rear - rear	3/4 - 16 UNF-2B SAE O-Ring
C4	Auxiliary port side - left side	3/4 - 16 UNF-2B SAE O-Ring
C5	Auxiliary port side - right side	3/4 - 16 UNF-2B SAE O-Ring
D1	Drain port - top	3/4 - 16 UNF-2B SAE O-Ring
D2	Drain port - bottom	3/4 - 16 UNF-2B SAE O-Ring
D3	Thru drain - rear	9.27 [.365] Dia.
D4	Thru drain - front	9.55 [.376] Dia.
S	Charge suction port	48/96 DP 45 class 1 side accepts a 3/4 - 16 UNF-2B SAE O-Rng

Same side porting (selected in position 9)

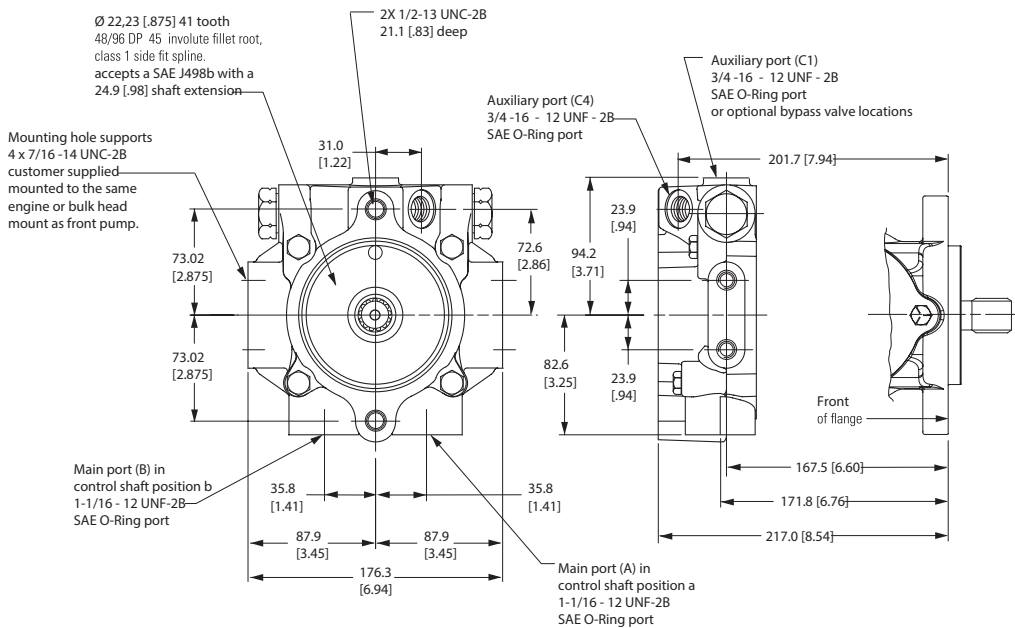

Features and port sizes

Model 72400

Drain locations in rear of pumps

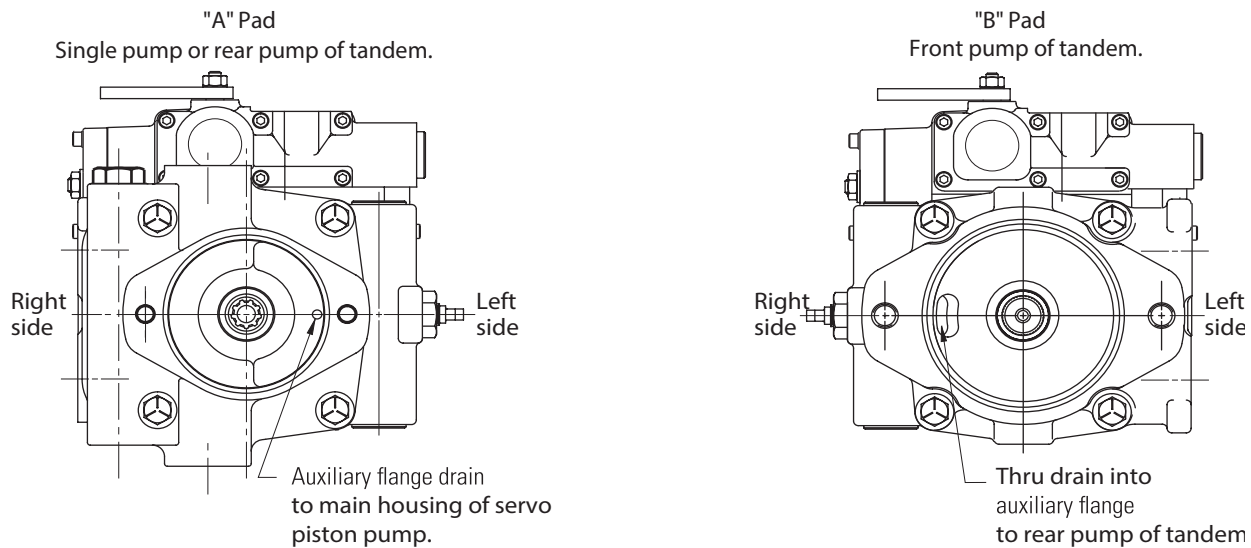

Side and front of pump

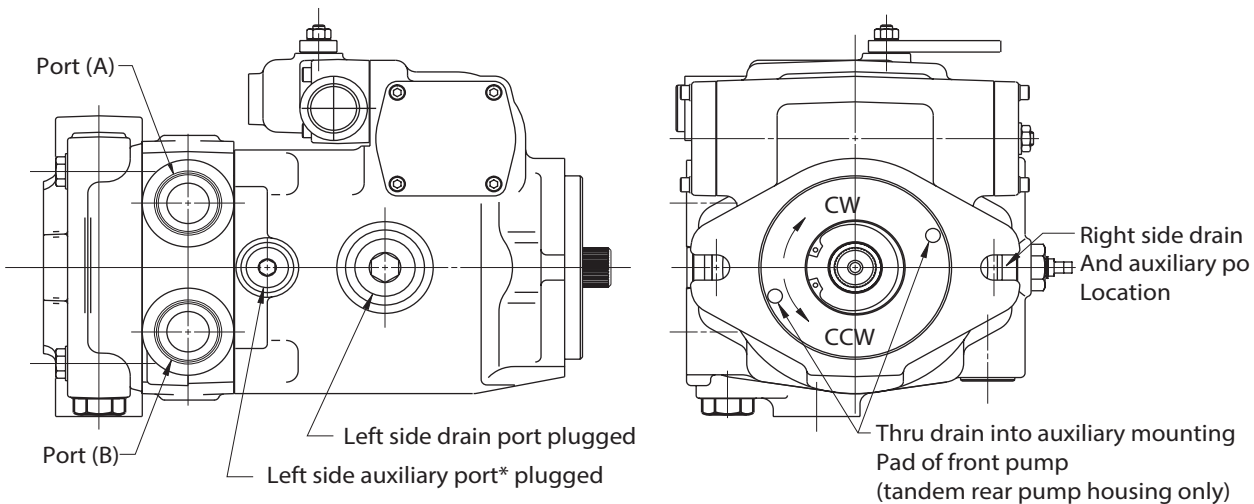

*Note: Auxiliary port required in rear and front pump of tandem to provide charge flow and pressure to front pump.

All left (CCW) or right (CW) directions given are viewed looking at the input shaft end of the pump.

(For dimensions, refer to installation drawings.)

Features and port sizes

Model 72400

Charge pump position must stay in relationship to backplate as pictured below.

*Righthand rotation (CW)

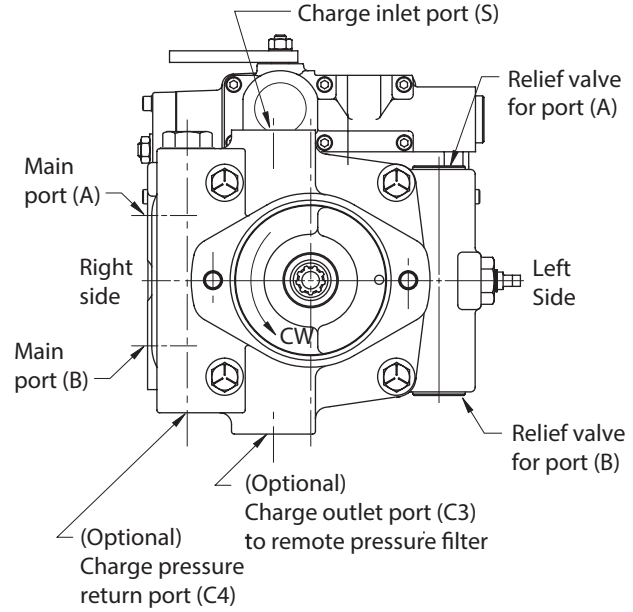
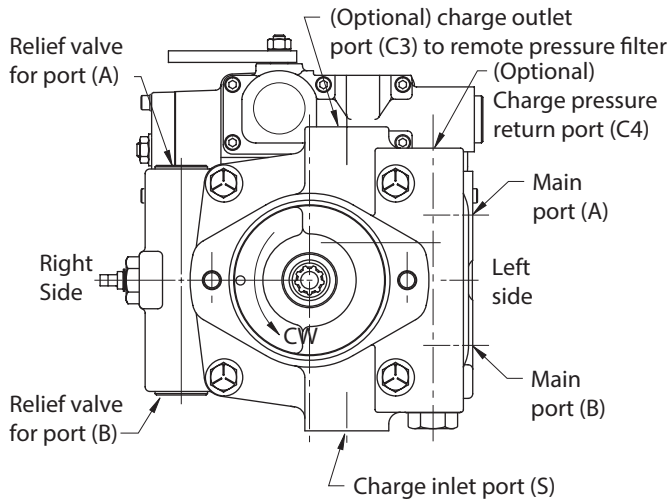

*Lefthand rotation (CCW)

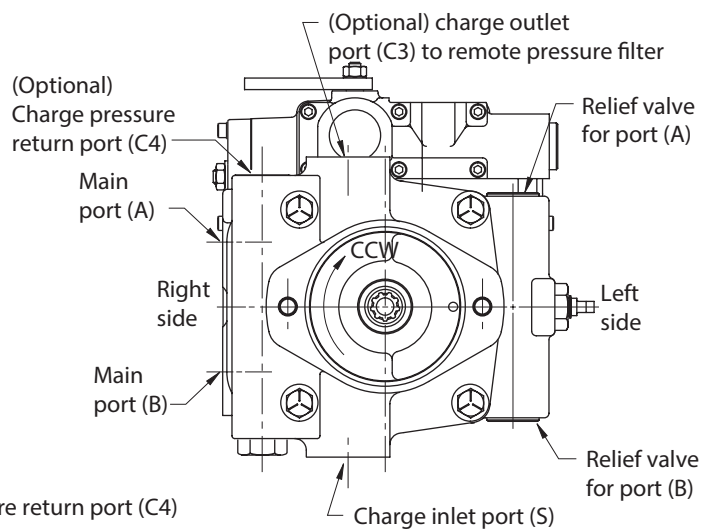
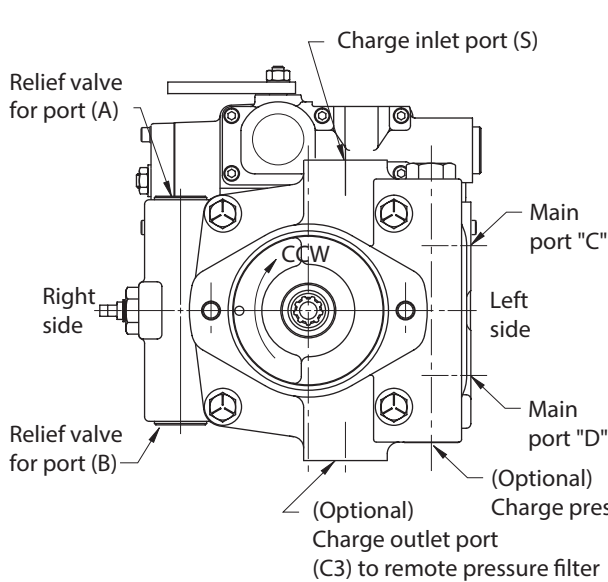

*All left (CCW) or right (CW) directions given are viewed looking at the input shaft end of the pump.

(For dimensions, refer to installation drawings.)

Features and port sizes

Model 72400 charge pump routing and location

Standard pump

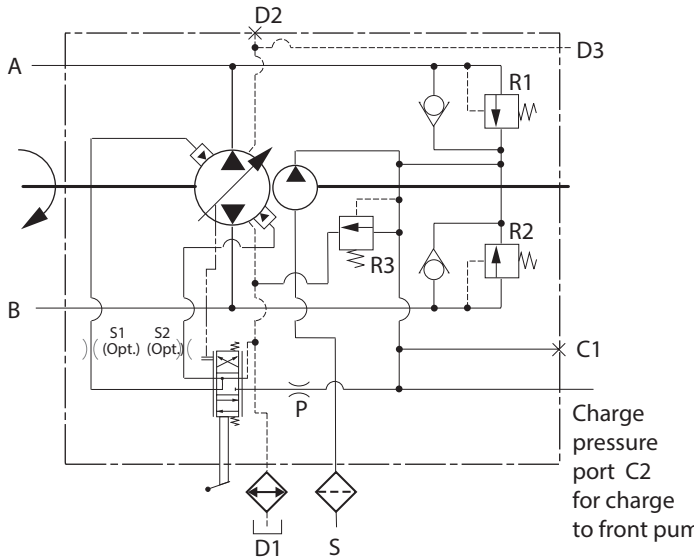

Charge pump with remote filter/ heat exchanger ports (Filter and heat exchanger supplied by customer.)

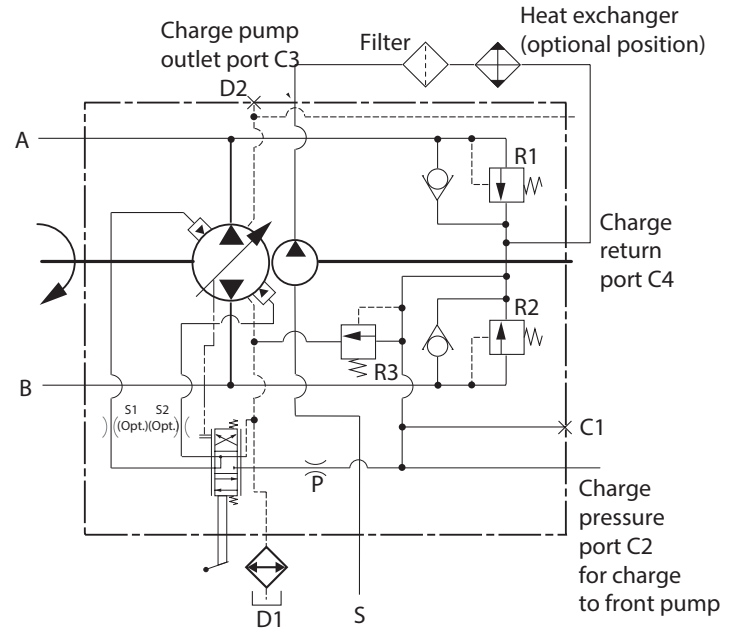

Charge outlet port location

The charge outlet and return port is located in the charge pump housing, opposite of the suction port and charge relief valve.

For further detail on port relationship to rotation and position, refer to installation drawings.

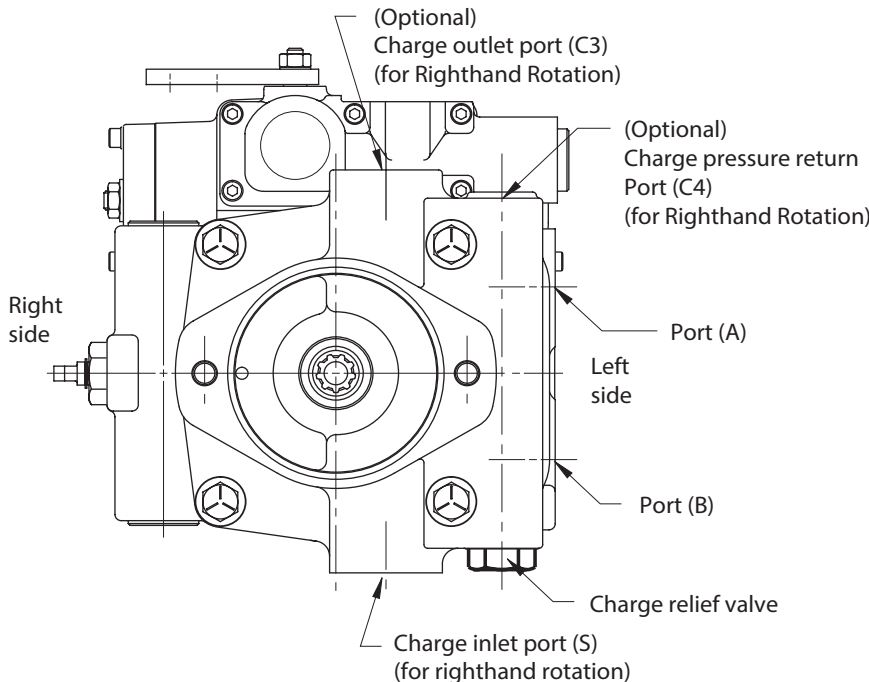

All left (CCW) or right (CW) directions given are viewed looking at the input shaft end of the pump.

Component selection

The long service life of Danfoss hydrostatic transmissions is largely dependent on the proper selection and installation of the components necessary for transmission operation.

The following components are necessary for transmission operation:

- Variable displacement pump
- Fixed or variable displacement motor
- Reservoir
- Filter
- Charge pump inlet line
- Pump and motor case drain lines
- High pressure lines
- Heat exchanger
- Heat exchanger bypass valve
- Reservoir return line

Variable displacement pump

Danfoss hydrostatic variable displacement pumps are an axial piston design. They are equipped with standard SAE mounts, shafts and port connections.

Fixed or variable displacement motor

Danfoss hydrostatic motors are an axial piston design. They are equipped with standard SAE mounts, shafts and port connections.

Sizing equations

For sizing/selecting the right pump for your application please carryout following basic calculations.

Flow requirements

Pump flow rate

$$\text{Pump displacements (DP)} = \frac{N_m \times D_m}{N_p \times \eta_p (\text{vol.}) \times \eta_m (\text{Vol.})}$$

Where,

N_m = Necessary loaded motor speed (RPM)

D_m = Motor displacement (in³/rev)

N_p = Pump input speed (RPM)

η_p (vol.) = Pump volumetric efficiency

η_m (vol.) = Motor volumetric efficiency

$$Q (\text{gpm}) = \frac{\text{Pump displacement (in}^3/\text{rev)} \times \text{Speed (rpm)} \times (\text{vol. eff.}) \times N_p \times \eta_p (\text{vol.}) \times \eta_m (\text{Vol.})}{231}$$

$$\text{Pump input power (HP)} = \frac{\text{Flow rate out put (GPM)} \times \text{Pressure (psi)}}{1714 \times \eta (\text{overall})}$$

Torque

$$\text{Torque (lbf-in)} = \frac{\text{Pump displacement (in}^3/\text{rev)} \times \text{Pressure (psi)}}{(2 \times \pi) \times \eta (\text{mech. eff.})}$$

Charge pump displacement

$$D = \frac{0.156 (n_p \times D_p + n_m \times D_m)}{2}$$

D_{cp} = Charge pump displacement

n_p = Number of pumps

n_m = Number of motors

D_p = Pump displacement

D_m = Motor displacement

Reservoir

The reservoir is an important part of the hydrostatic transmission system. It should provide adequate oil storage and allow easy oil maintenance.

The reservoir must hold enough oil to provide a continuous oil supply to the charge pump inlet. It must also have enough room for the hydraulic oil to expand as the system warms up. Consider charge pump flow when sizing the reservoir: One half (.5) minute times (X) the maximum charge pump flow should be the minimum oil volume in the reservoir. Maintaining this oil volume will give the oil a minimum of thirty (30) seconds in the reservoir. This will allow any entrained air to escape and contamination to settle out of the oil.

To allow for oil expansion, the reservoir's total volume should be at least six tenths (.6) minute times (X) the maximum charge pump flow.

The reservoir's internal structure should cut down turbulence and prevent oil aeration.

The line returning flow to the reservoir should be fitted with a diffuser to slow the incoming oil to 1 to 1.2 meters [3-4 feet] per second to help reduce turbulence. The return flow line should also be positioned so that returning oil enters the reservoir below the liquid surface. This will help reduce aeration and foaming of the oil.

The reservoir should have baffles between the return line and suction line. Baffles prevent return flow from immediately reentering the pump.

A sixty mesh screen placed across the suction chamber of the reservoir will act as a bubble separator. The screen should be placed at a 30° angle to the horizon.

The entrance to the suction line should be located well below the fluid surface so there is no chance of air being drawn into the charge pump inlet. However, the suction line entrance should not be located on the bottom of the reservoir where there may be a buildup of sediment. The suction line entrance should be flared and covered with a screen.

The reservoir should be easily accessible. The fill port should be designed to minimize the possibility of contamination during filling and to help prevent over filling. There should be a drain plug at the lowest point of the reservoir and it should also have a clean-out and inspection cover so the reservoir can be thoroughly cleaned after prolonged use. A vented reservoir should have a breather cap with a micronic filter.

Sealed reservoirs must be used at altitudes above 2500 feet. These reservoirs should be fitted with a two-way micronic filter pressure cap to allow for fluid expansion and contraction.

In both cases the caps must be designed to prevent water from entering the reservoir during bad weather or machine washing.

A hydrostatic transmission with a well designed reservoir will run quieter, stay cleaner and last longer.

Component selection

Filter

A filter must be used to keep the hydraulic fluid clean. Either a suction filter or a pressure side filter may be used. The filter must be a no-bypass type. System oil particle levels should not exceed ISO 18/15 per ISO 4406. Refer to Danfoss hydraulic fluid recommendations.

Recommended filters

Pressure line – 5 micrometer

Suction line = 3 OR 5 micrometer

When a suction filter is used, its flow capacity must be large enough to prevent an excessive pressure drop between the reservoir and charge pump inlet. The pressure at the charge pump inlet port must not be less than 0.80 bar absolute [6 in. Hg.] at normal continuous operating temperatures

Charge pump inlet line

The inlet line to the charge pump should be large enough to keep the pressure drop between the reservoir and charge pump inlet within the limits described in the filter section. Fittings will increase the pressure drop, so their number should be kept to a minimum. It is best to keep fluid velocities below 1.25 meters [4 feet] per second.

Fluid and temperature compatibility must be considered when selecting the inlet line.

Pump and motor case drain

The case drain lines should be large enough to limit the pump and motor case pressures (Medium Duty to 2 bar [25 PSI]) at normal operating temperatures. Fluid and temperature compatibility must also be considered when selecting the case drain lines.

High pressure lines

The high pressure lines that connect the pump and motor must be able to withstand the pressures generated in the high pressure loop.

Heat exchanger

Use of a heat exchanger is dependent on the transmission's duty cycle and on machine layout. The normal continuous operating fluid temperature measured in the pump and motor cases should not exceed 80°C [180°F] for most hydraulic fluids. The maximum fluid temperature should not exceed 107°C [225°F].

The heat exchanger should be sized to dissipate 25% of the maximum input power available to the transmission. It must also be sized to prevent the case pressures in the pump and motor from getting too high. Medium duty case pressure up to 2 bar [25 psi], at normal operating temperatures, are acceptable.

Heat exchanger bypass valve

The heat exchanger bypass valve is a pressure and/or temperature valve in parallel with the heat exchanger. Its purpose is to prevent case pressures from getting too high. The heat exchanger bypass valve opens when the oil is thick, especially during cold starts.

Reservoir return line

The same general requirements that apply to case drain lines apply to the reservoir return line.

Bearing life estimation

Bearing life is defined as the length of time in terms of revolutions or time until a fatigue failure. Bearing load is calculated as a reaction which is derived from the moment created by the piston side load. Magnitude of the side load directly related to the speed and pressure at which a unit can be operated.

Bearing life is a function of the side loads coming on the bearings. Other factors such as fluid type, viscosity of fluid and cleanliness also affects the life of bearing.

If detail bearing life analysis is required, you can contact Danfoss representative.

Installation requirements

The mounting orientation of pumps and motors is unrestricted provided the case drain of the pump and motor remain full. Position the case drain such that it assures an oil level at or above unit center line at start-up. The case drain line that carries the flow leaving the pump or motor should be connected to the highest drain port on each of the units. This assures that the pump and motor cases remain full.

The combined torque required to turn two or more pumps must not exceed the torque rating of the input drive shaft of the front piston pump. Installer to provide centering and a secure neutral for pump swashplate control shaft. An external support is recommended for all tandems.

Open loop circuits

Danfoss pumps and motors may be used in open loop circuits under certain operating conditions. Consult your Danfoss representative for details.

Hydraulic fluid recommendations

Introduction

Hydraulic fluids are one of the vital components of hydraulic system. Proper selection of oil assures satisfactory life and operation of system components. The purpose of this section is to provide readers with the knowledge required to select the appropriate fluids for use in systems that employ Danfoss hydraulic components

Viscosity and temperature

Viscosity is the measure of a fluid's resistance to flow. The most important characteristics to consider when choosing a fluid to be used in a hydraulic system is viscosity. The fluid must be thin enough to flow easily but thick enough to maintain adequate lubricating film between components and to maintain proper sealing at the operating temperatures of the hydraulic system.

For viscosity requirements, see table

Viscosity of any fluid is relative to temperature, as the fluid warms the viscosity decreases and vice versa. When choosing a fluid, it is important to consider the start-up and operating temperatures of the hydraulic system. A high VI fluid shows relatively small change of viscosity with temperature.

Lubricants used for hydraulic applications may contain viscosity index improvers (VII). They refer to these fluids as viscosity index improved or multi-viscosity fluids. The viscosity of these fluids may drop down in use due to shearing of VI improvers used in the formulations.

Anti-wear hydraulic oils containing polymeric thickeners, viscosity index improvers (VII) are generally used for wide band operating temperature applications. These fluids experience temporary and permanent viscosity loss during use in hydraulic system. Check the extent of viscosity loss (shear stability) to avoid hydraulic service below the recommended minimum viscosity. Oil with good shear stability is recommended for wide band temperature applications.

Multi-grade engine oils, ATFs, UTTOs, etc., also contain VIIs, and viscosity loss will be encountered during use.

Cleanliness

Cleanliness of the fluid in a hydraulic system is extremely important. More than 70% of all failures are caused by contamination. Danfoss recommends that the fluid used in its hydraulic components be maintained per ISO 4406. Cleanliness level requirements vary with the hydraulic components. The cleanliness of a hydraulic system is dictated by the cleanliness requirements of the most stringent component in the system.

Cleanliness requirements for specific products are given in the table.

OEM's and distributors who use Danfoss hydraulic components in their hydraulic systems should provide these requirements in their designs.

Contact Danfoss filter representative for filtration information.

Fluid maintenance

The condition of a fluid has a direct effect on the performance and reliability of the system. Maintaining proper fluid viscosity, cleanliness level, water content, and additive level is essential for excellent hydraulic system performance. Routine fluid condition monitoring is recommended.

Fluid selection

Premium grade anti-wear (AW) petroleum based hydraulic fluids will provide the best performance with Danfoss hydraulic components. Fluids that meet Danfoss Hydraulic Fluid Specification E-FDGN-TB002-E are considered good quality anti-wear hydraulic fluids. These fluids pass Danfoss Vickers[®] 35VQ25A high pressure vane pump test (Danfoss ATS-373 test procedure, ASTM D 6973).

Automotive crank case oils with American Petroleum Institute (API) letter designation SF, SG, SH, SJ, or higher per SAE J 183 classes of oils are recommended for applications using Danfoss DG valves. Automotive crankcase oils generally exhibit less shear stability compared to industrial anti-wear hydraulic fluids, which can result in higher loss of viscosity during service life.

Other mineral oil based lubricants commonly used in hydraulic systems are automatic transmission fluids (ATF) and universal tractor transmission oils (UTTO).

Synthetic hydrocarbon base stocks, such as polyalphaolefins (PAO) are also used to formulate hydraulic fluids, engine oils, ATFs and UTTOs. Alternate fluids are recommended when specific properties, such as fire resistance, biodegradability, etc., are necessary for the application. Keep in mind that alternative fluids may differ from AW petroleum fluids in properties.

Additional notes

When choosing a hydraulic fluid, all the components in the system must be considered. Viscosity limitations have to meet the most stringent component requirements.

For any system where the fluid is non-petroleum oil, set the target one ISO code cleaner for each particle size, than that of petroleum fluids.

Keep adequate fluid level in the reservoir. Take fluid level reading when the system is cold.

Contact your Danfoss representative, if you have specific questions about the fluid requirements of Danfoss hydraulic components.

Hydraulic fluid recommendations

Viscosity & cleanliness recommendation

Product	Minimum *	Optimum	Maximum	ISO Cleanliness
Medium duty piston pumps And motors charged systems	6.0 cSt (45 SUS)	10 – 39 cSt (60-180 SUS)	2158 cSt (10000 SUS)	21/18/13

Additional notes

- Fluids too thick to flow in cold weather start-ups will cause pump cavitation and possible damage. Motor cavitation is not a problem during cold start-ups, except for two speed motors. Thick oil can cause high case pressures which in turn cause shaft seal problems
- When choosing a hydraulic fluid, all the components in the system must be considered and the optimum viscosity range adjusted accordingly. For example, when a medium duty piston pump is combined with a Disk Valve Motor the optimum viscosity range becomes 100 - 180 SUS [20 - 39 cSt] and viscosity should never fall below 70 SUS [13 cSt]
- If the natural color of the fluid has become black it is possible that an overheating problem exists.
- If the fluid becomes milky, water contamination may be a problem
- Take fluid level reading when the system is cold.
- Contact your Danfoss representative if you have specific questions about the fluid requirements of Danfoss hydraulic components

Products we offer:

- Cartridge valves
- DCV directional control valves
- Electric converters
- Electric machines
- Electric motors
- Gear motors
- Gear pumps
- Hydraulic integrated circuits (HICs)
- Hydrostatic motors
- Hydrostatic pumps
- Orbital motors
- PLUS+1® controllers
- PLUS+1® displays
- PLUS+1® joysticks and pedals
- PLUS+1® operator interfaces
- PLUS+1® sensors
- PLUS+1® software
- PLUS+1® software services, support and training
- Position controls and sensors
- PVG proportional valves
- Steering components and systems
- Telematics

Danfoss Power Solutions is a global manufacturer and supplier of high-quality hydraulic and electric components. We specialize in providing state-of-the-art technology and solutions that excel in the harsh operating conditions of the mobile off-highway market as well as the marine sector. Building on our extensive applications expertise, we work closely with you to ensure exceptional performance for a broad range of applications. We help you and other customers around the world speed up system development, reduce costs and bring vehicles and vessels to market faster.

Danfoss Power Solutions – your strongest partner in mobile hydraulics and mobile electrification.

Go to www.danfoss.com for further product information.

We offer you expert worldwide support for ensuring the best possible solutions for outstanding performance. And with an extensive network of Global Service Partners, we also provide you with comprehensive global service for all of our components.

Local address:

Hydro-Gear

www.hydro-gear.com

Daikin-Sauer-Danfoss

www.daikin-sauer-danfoss.com

**Danfoss
Power Solutions (US) Company**
2800 East 13th Street
Ames, IA 50010, USA
Phone: +1 515 239 6000

**Danfoss
Power Solutions GmbH & Co. OHG**
Krokamp 35
D-24539 Neumünster, Germany
Phone: +49 4321 871 0

**Danfoss
Power Solutions ApS**
Nordborgvej 81
DK-6430 Nordborg, Denmark
Phone: +45 7488 2222

**Danfoss
Power Solutions Trading
(Shanghai) Co., Ltd.**
Building #22, No. 1000 Jin Hai Rd
Jin Qiao, Pudong New District
Shanghai, China 201206
Phone: +86 21 2080 6201